

アップロー

パーツリスト

APL-500-4M

APL-350-4M (スライドフォークタイプ)

●部品調達平均所要日数

No.部の色分けにて納期の目安を記しています。

実際の納期は都度お問い合わせ願います。

尚、下記表記載の所要日数はメーカーにおける部品調達日数であり、別途、5営業日の配送日数（海外からの調達日数を含む）を要します。

	30~90日以内にメーカーより発送
	10~30日以内にメーカーより発送
	5~10日以内にメーカーより発送
	3~5日以内にメーカーより発送

目 次

STICKER	3
DRIVE ASSEMBLY	5
HANDLE BAR	7
OUTRRIGER / SIDE & FRONT WHEEL	9
ELECTRICAL SYSTEM	11
1) CONTROL SYSTEM	11
2) CONTROL BOX	13
3) CONTACTOR PANEL / RELAY ASSEMBLY	15
HYDRAULIC PART	17
MAST PART(APL-500-4M)	19
MAST PART(SLIDE FORK TYPE)	21
1) IN MAST	21
2) MIDDLE MAST	23
3) OUT MAST	25
FORK PART(APL-500-4M)	27
FORK PART (SLIDE FORK TYPE)	29
SLIDE FORK (SLIDE FORK TYPE)	31

STICKER

①



②

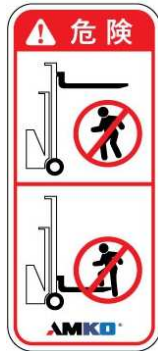

③



④



⑤

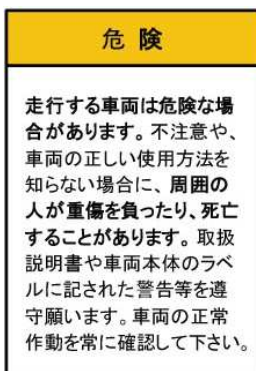

⑥

後進時衝突注意

⑦

DRIVE

⑧

SLOPE ERR

⑨

CHARGER

⑩

CHARGER CABLE

⑪

LASER POINTER

⑫

0°

⑬

90°

STICKER

NO.	パーツNo.	名 称	Q'TY	備 考
1	S1-01	AMKO	2	
2	S1-02	危険	2	
3	S1-03	危険	1	
4	S1-04	運転前注意事項	1	
5	S1-06	危険	1	
6	S1-07	後進時注意事項	1	
7	S1-09	DIRVE	1	
8	S1-10	SLOPE ERR	1	
9	S1-11	CHARGER	1	
10	S1-12	CHARGER CABLE	1	
11	S1-13	LASER POINTER	1	
12	S1-14	0°	1	
13	S1-15	90°	1	

DRIVE ASSEMBLY

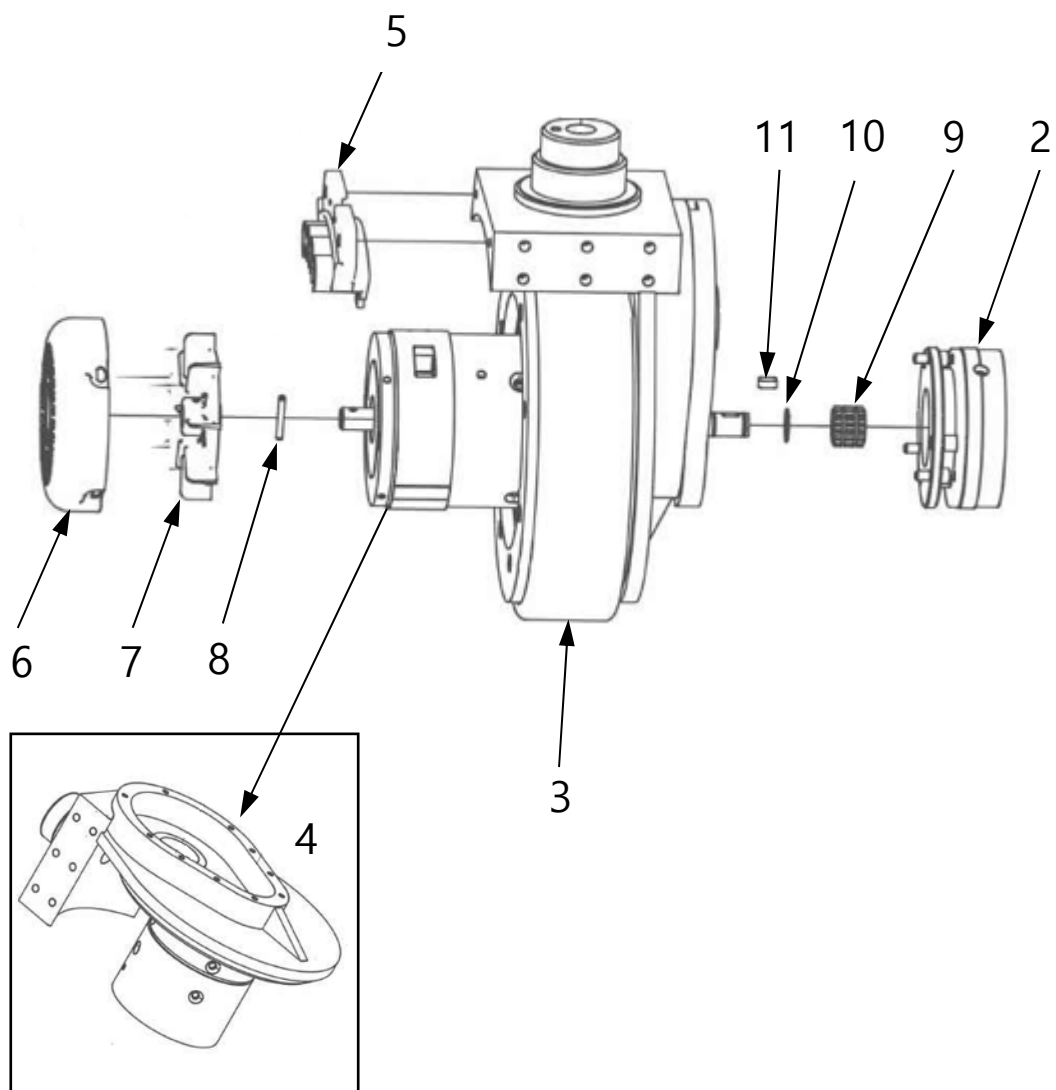
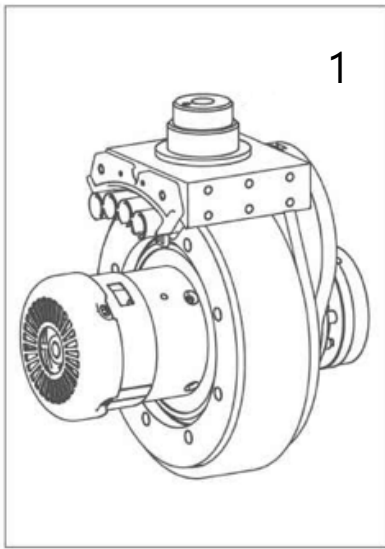

DRIVE ASSEMBLY

NO.	パーツNo.	名 称	Q'TY	備 考
1	DR-001	DRIVE ASS'Y	1	
2	DR-EL002	BRAKE	1	
3	DR-W001	DRIVE WHEEL	1	
4	DR-M001	DRIVE MOTOR	1	
5	DR-ELH01	EAR	1	
6	DR-FC01	FAN COVER	1	
7	DR-FAN	FAN	1	
8	DR-FP01	ELASTIC PIN	1	
9	DR-G01	SPLINE	1	
10	SN-S05	SNAPRING	1	
11	DR-K01	KEY	1	

HANDLE BAR

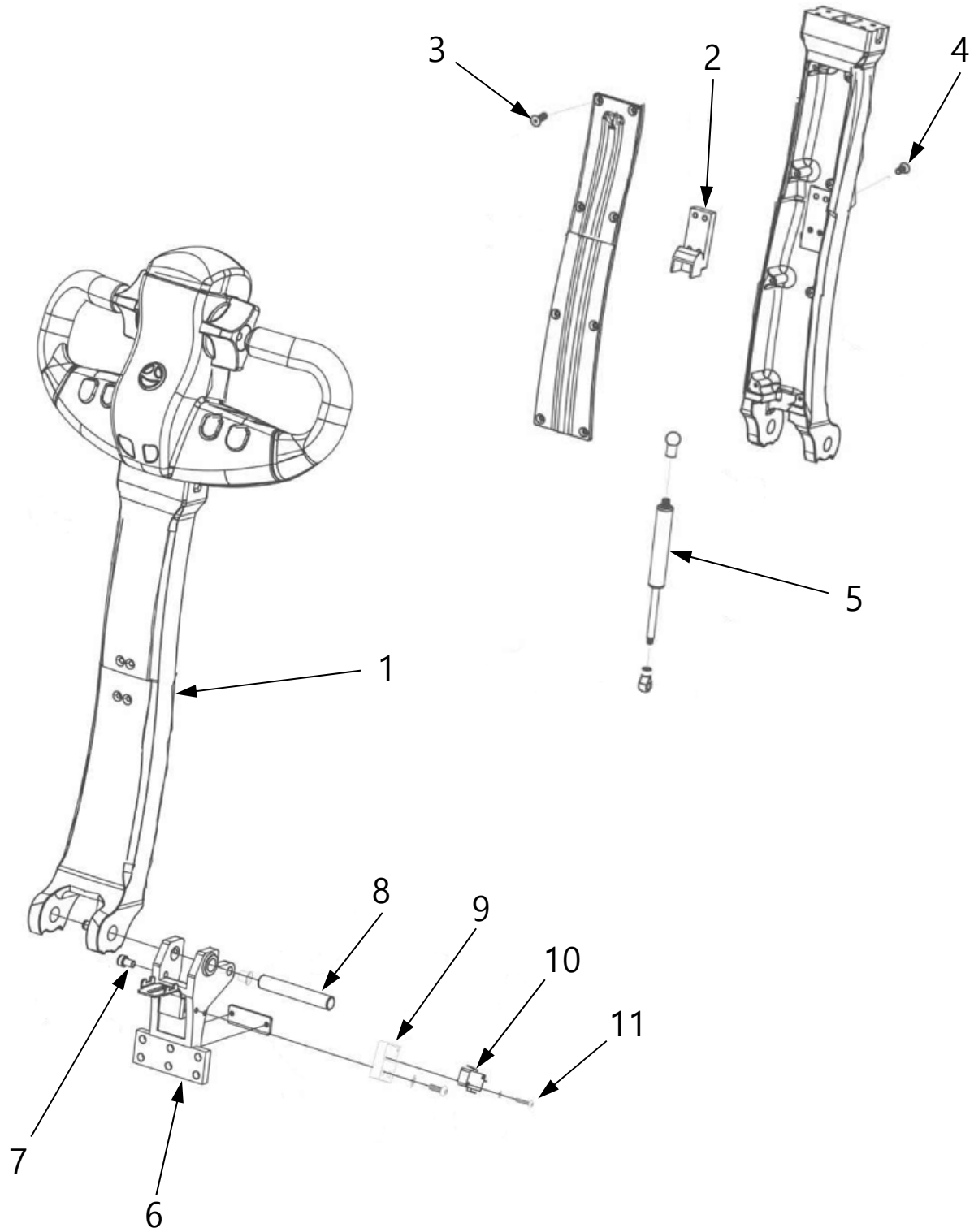

HANDLE BAR

NO.	パーツNo.	名 称	Q'TY	備 考
1	DR-HD01	HANDLE BAR	1	
2	DR-HD02	SHOCK ABSORBER BRACKET	1	
3	BT- HDB1	BOLT	8	
4	BT- HDB2	BOLT	4	
5	DR-SA001	HANDLE SHOCK ABSORBER	1	
6	DR-HD03	HANDLE SOCKET	1	
7	DR-B001	HANDLE STOPPER	1	
8	DR-BDP01	PIN	1	
9	DR-BD04	S/W BRACKET	1	
10	DR-EL001	INTER LOCK S/W	1	
11	DR-HDB3	BOLT	2	

OUTTRIGGER / SIDE & FRONT WHEEL

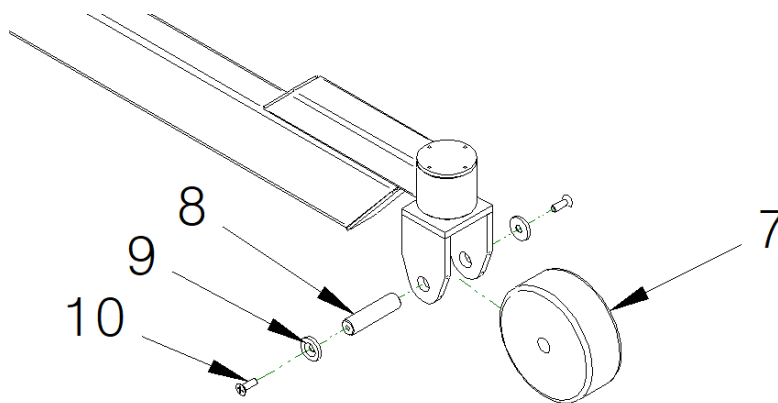
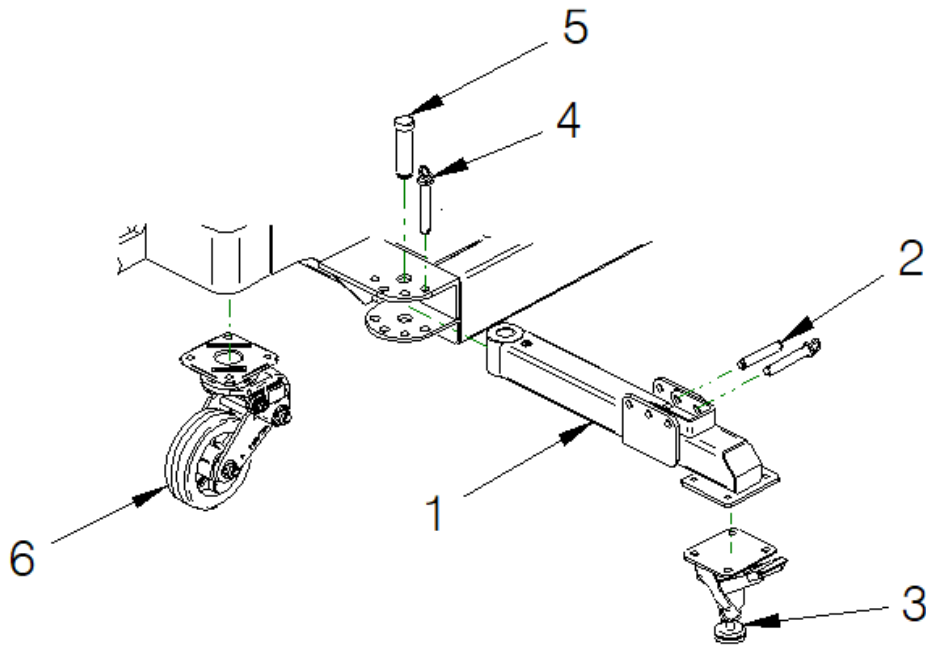

OUTTRIGGER / SIDE & FRONT WHEEL

NO.	パーツ№.	名 称	Q'TY	備 考
1	BD-OUT	OUTRIGGER ASS'Y	2	
2	BD-OP01	PIN	2	
3	CM-003	FLOOR LOCK	2	
4	BD-OP03	PIN	4	
5	BD-OP02	PIN	2	
6	DR-W002	SIDE WHEEL	2	
7	DR-W003	FRONT WHEEL	2	
8	DR-WP01	PIN	2	
9	DR-WPW1	WASHER	4	
10	BT-M8	BOLT	4	

ELECTRICAL SYSTEM

1) CONTROL SYSTEM

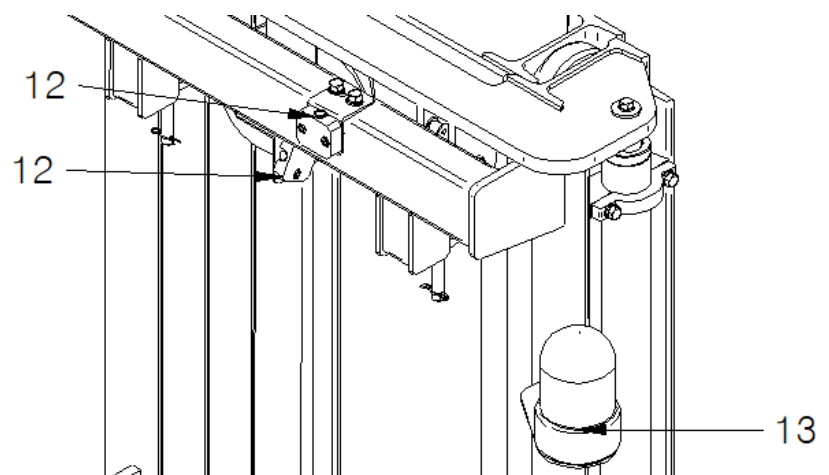
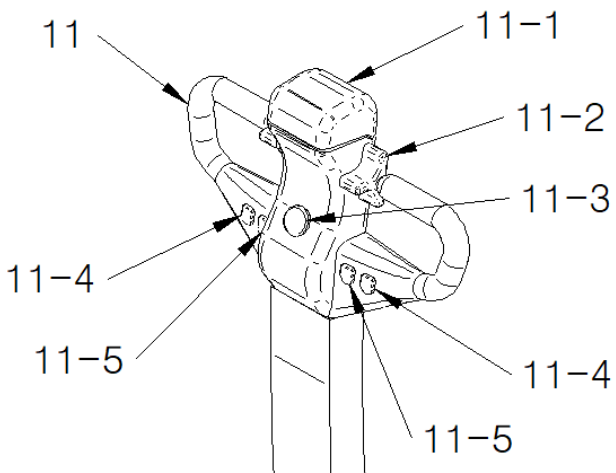
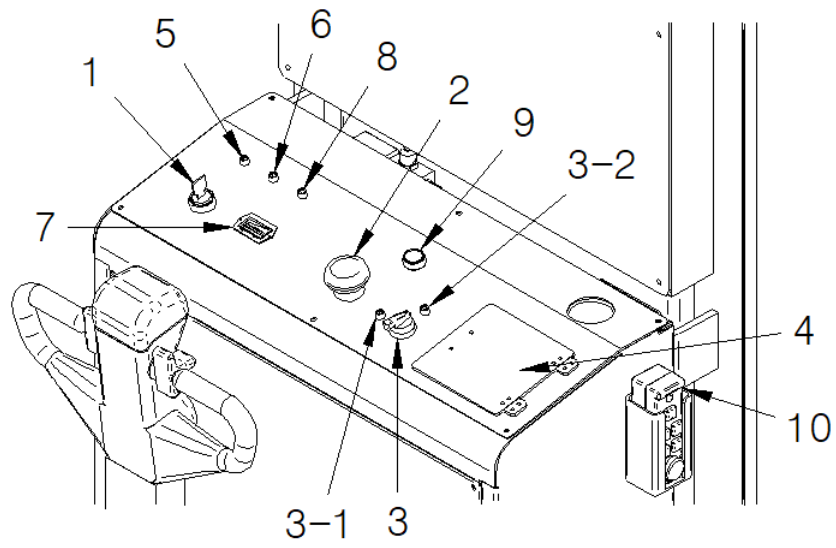

1) CONTROL SYSTEM

NO.	パーツNo.	名 称	Q'TY	備 考
1	EL-401	KEY SWITCH	1	
2	EL-002	EMERGENCY SWITCH	1	
3	EL-003	0°, 90° SWITCH	1	
3-1	EL-004	LED(RED) M8	1	
3-2	EL-005	LED(GREEN) M8	1	
4	EL-006	CHAGER CABLE	1	コンセント含まず
5	EL-004	LED(RED) M8	1	
6	EL-005	LED(GREEN) M8	1	
7	EL-007	BDI	1	
8	EL-008	CHAGER LED	1	
9	EL-009	LASER BUTTON	1	
10	EL-RM01-1	WIRELESS REMOTE	1	
11	EL-D001	HANDEL LEVER ASS'Y	1	
11-1	EL-D002	EMERGENCY BUTTON	1	
11-2	EL-D003	DRIVE LEVER	1	
11-3	EL-D004	HORN BUTTON	1	
11-4	EL-D005	UP BUTTON	2	
11-5	EL-D006	DOWN BUTTON	2	
12	EL-LA01	LASER	4	
13	EL-WL01	WARNING LIGHT	1	※キャップのみは10個ロットにて販売可

2) CONTROL BOX

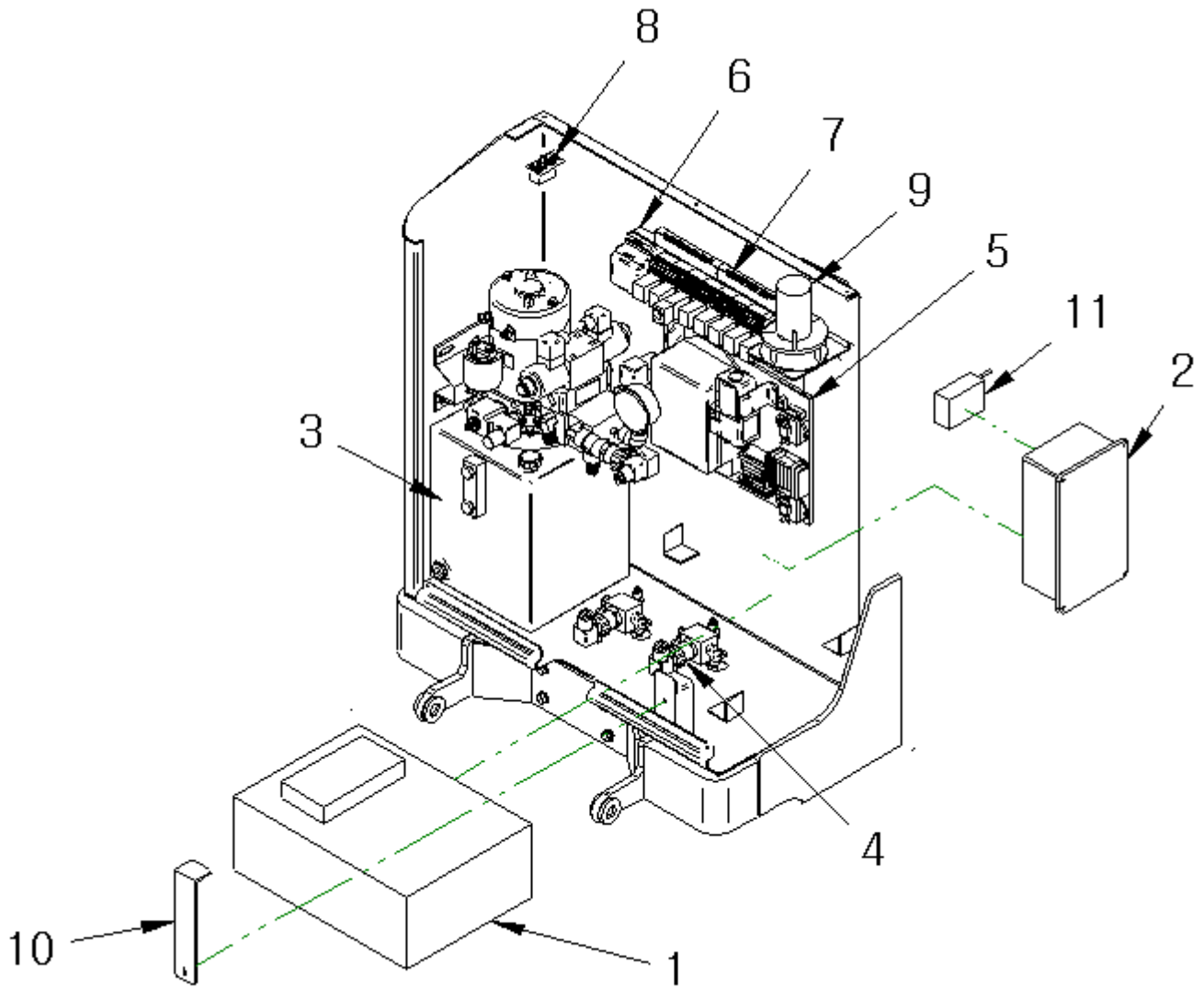

2) CONTROL BOX

NO.	パーツNo.	名 称	Q'TY	備 考
1	EL-BL24075	BATTERY	1	
2	EL-CH410	CHAGER	1	
3	EL-PW01	POWER PACK	1	
4	HD-P001	PRESSURE SENSOR	2	
5	-	CONTACTOR PANEL	1	
6	-	RELAY ASSEMBLY	1	
7	-	TERMINAL BLOCK ASSEMBLY	1	
8	EL-013	LOCK CYLINDER TOGGLE S/W	1	
9	EL-L001	LEVEL SENSOR	1	
10	BD-BB01	BATTERY HOLDER	1	
11	EL-RM01	REMOTE CONTROL RECEIVER	1	

3) CONTACTOR PANEL / RELAY ASSEMBLY

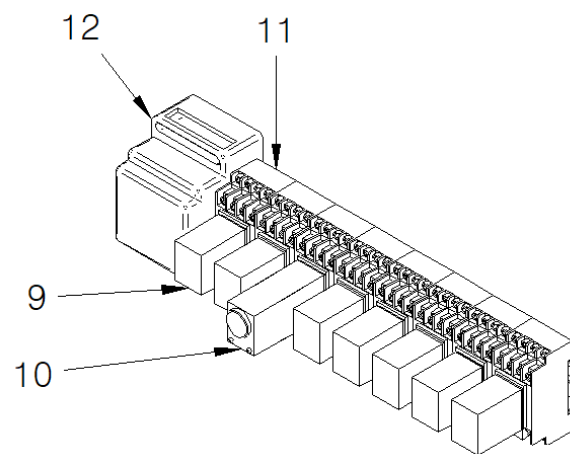
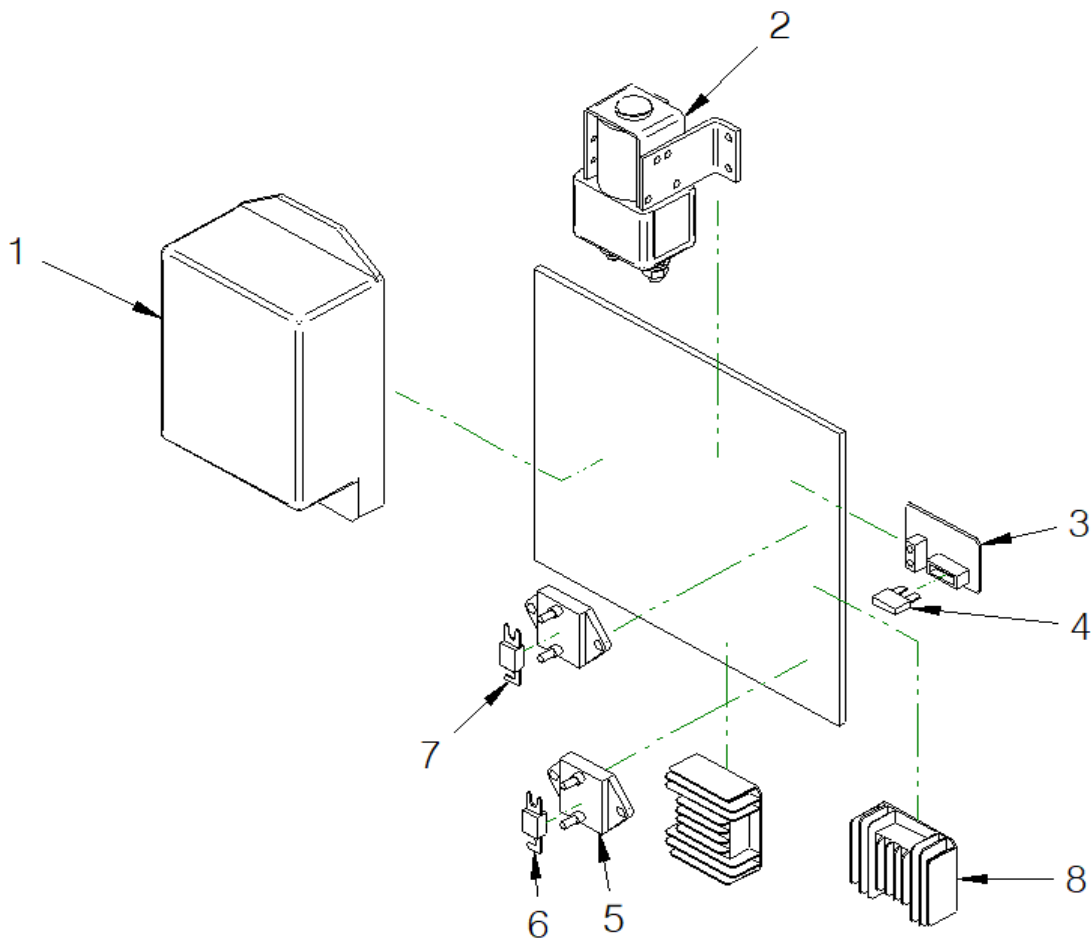

3) CONTACTOR PANEL / RELAY ASSEMBLY

NO.	パーツNo.	名 称	Q'TY	備 考
1	EL-012	CONTROLLER	1	
2	EL-011	MAGNETIC CONTACTOR	1	
3	EL-BOD	CIRCUIT BOARD	1	
4	EL-H003	FUSE	1	
5	EL-HH01	FUSE HOLDER	2	
6	EL-H001	FUSE	1	
7	EL-H002	FUSE	1	
8	EL-010	DOWN CONVERTER	2	DC 24V→12V
9	EL-R002	RELAY (14PIN)	7	
10	EL-R001	TIME RELAY (14PIN)	1	
11	EL-RH01	RELAY HOLDER	8	

HYDRAULIC PART

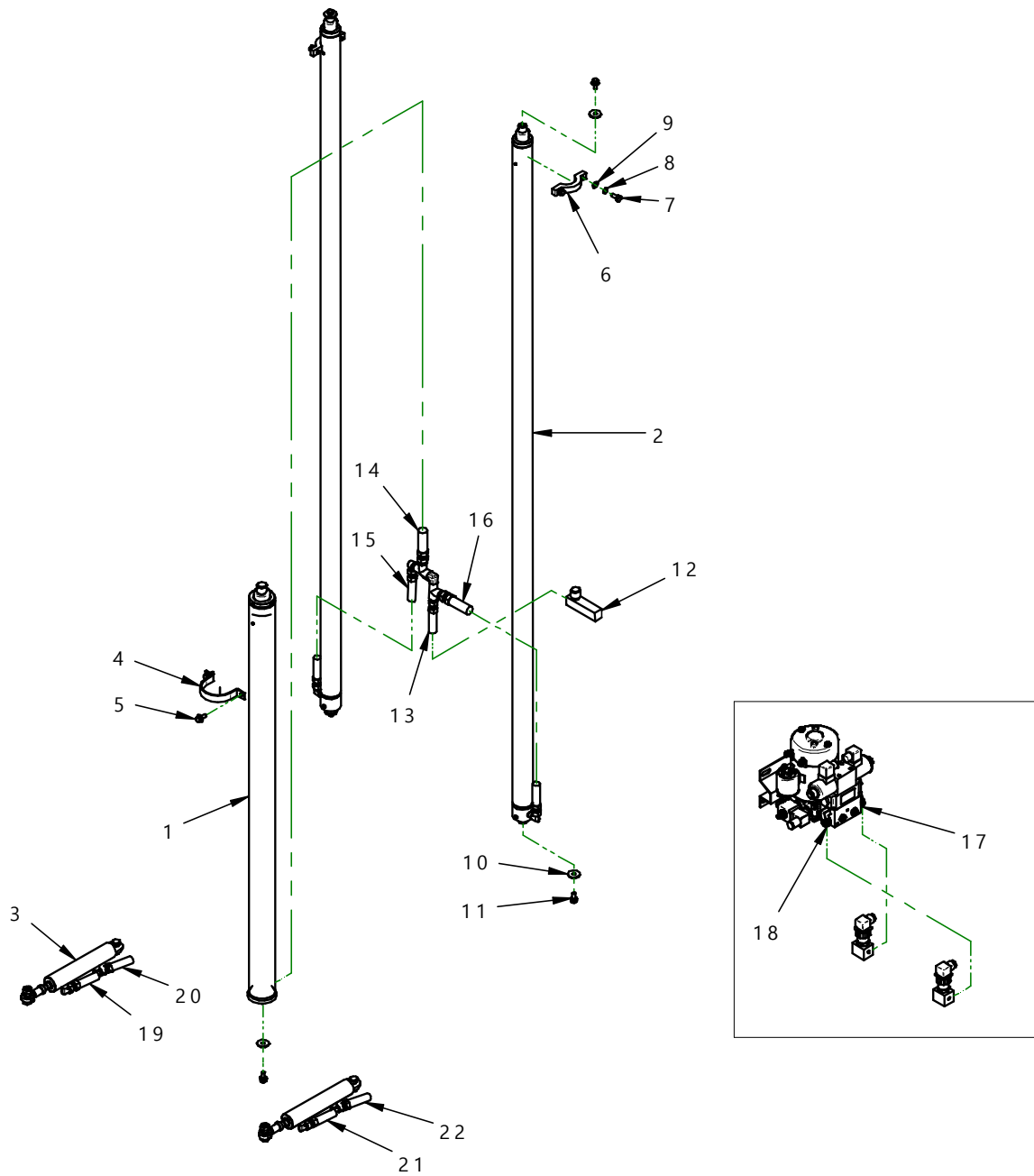

HYDRAULIC PART

NO.	パーツNo.	名 称	Q'TY	備 考
1	CY-401	CENTER CYLINDER	1	
2	CY-402	SIDE CYLINDER	2	
3	CY-403	0°, 90° TILT CYLINDER	2	
4	MA-CB01	CENTER CYLINDER CLAMP	1	
5	BT-M8	BOLT	2	
6	MA-CB02	SIDE CYLINDER CLAMP	2	
7	BT-M8	BOLT	4	
8	PW-M8	PLAN WASHER	4	
9	SW-M8	SPRING WASHER	4	
10	-	SPACER	5	
11	BT-M8	BOLT	5	
12	HD-B001	SPEED CONTROL VALVE	1	
13	HD-HS01	MAIN HOSE	1	
14	HD-HS02	CENTER CYLINDER HOSE	1	
15	HD-HS03	SIDE CYLINDER HOSE(RH)	1	
16	HD-HS04	SIDE CYLINDER HOSE(LH)	1	
17	HD-HS05	0° MAIN HOSE	1	
18	HD-HS06	90° MAIN HOSE	1	
19	HD-HS07	0° TILT HOSE(RH)	1	
20	HD-HS08	90° TILT HOSE(RH)	1	
21	HD-HS09	0° TILT HOSE(LH)	1	
22	HD-HS10	90° TILT HOSE(LH)	1	

MAST PART(APL-500-4M)

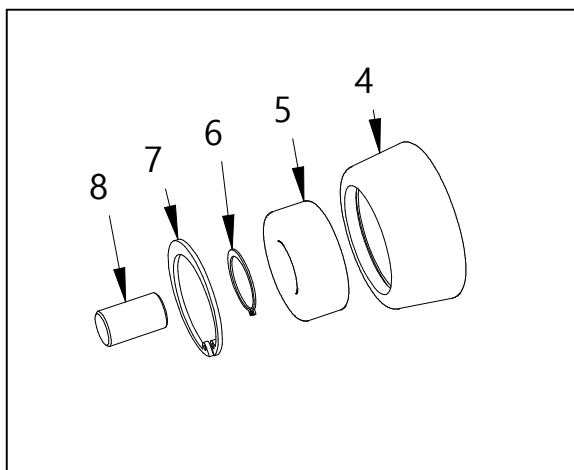
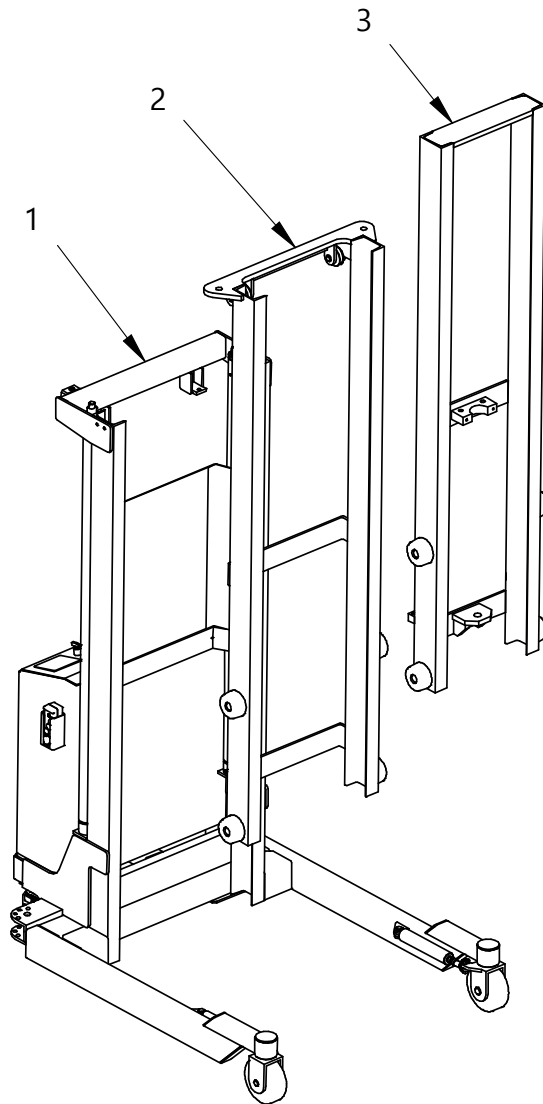

MAST PART(APL-500-4M)

ITEM NO.	PART NUMBER	DESCRIPTION	Q'TY	REMARKS
1	BD-001	BODY FRAME	1	工場修理対象部品
2	MA-401	MIDDLE MAST	1	工場修理対象部品
3	MA402	IN MAST	1	工場修理対象部品
4	MA-R01	MAST & FORK ROLLER	12	
5	BR-001	BEARING(6206)	12	
6	SN-R01	SNAP RING	12	
7	SN-C01	SNAP RING	12	
8	CM-002	SIDE MC	12	
9				
10				
11				
12				
13				
14				
15				
16				
17				
18				
19				

MAST PART(SLIDE FORK TYPE)

1) IN MAST

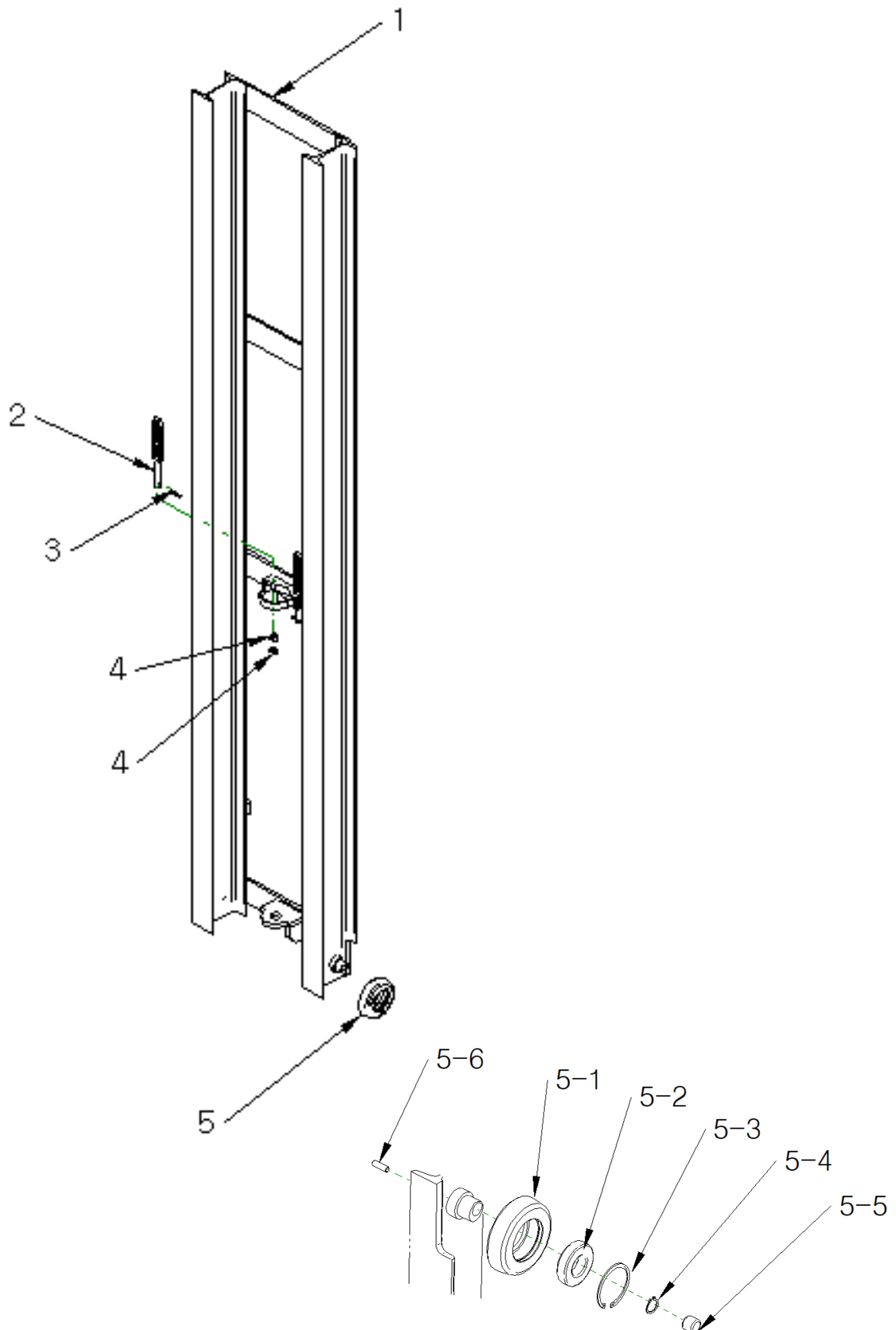

MAST PART(SLIDE FORK TYPE)

1) IN MAST

NO.	パーツNo.	名 称	Q'TY	備 考
1	MA-412	IN MAST	1	工場修理対象部品
2	CHA-001	FORK CHAIN ASS'Y	2	
3	-	R-PIN	4	
4	NT-M12	NUT	8	
5	MA-R601	MAST ROLLER ASS'Y	2	フォークローラー共用 ベアリング、スナップ リング含む
5-1	MA-R6001	ROLLER	2	
5-2	BR-001	BEARING	2	
5-3	SN-R01	SNAP RING	2	
5-4	SN-C01	SNAP RING	2	
5-5	CM-002	SIDE MC	2	
5-6	MBT-M8	BOLT	2	

2) MIDDLE MAST

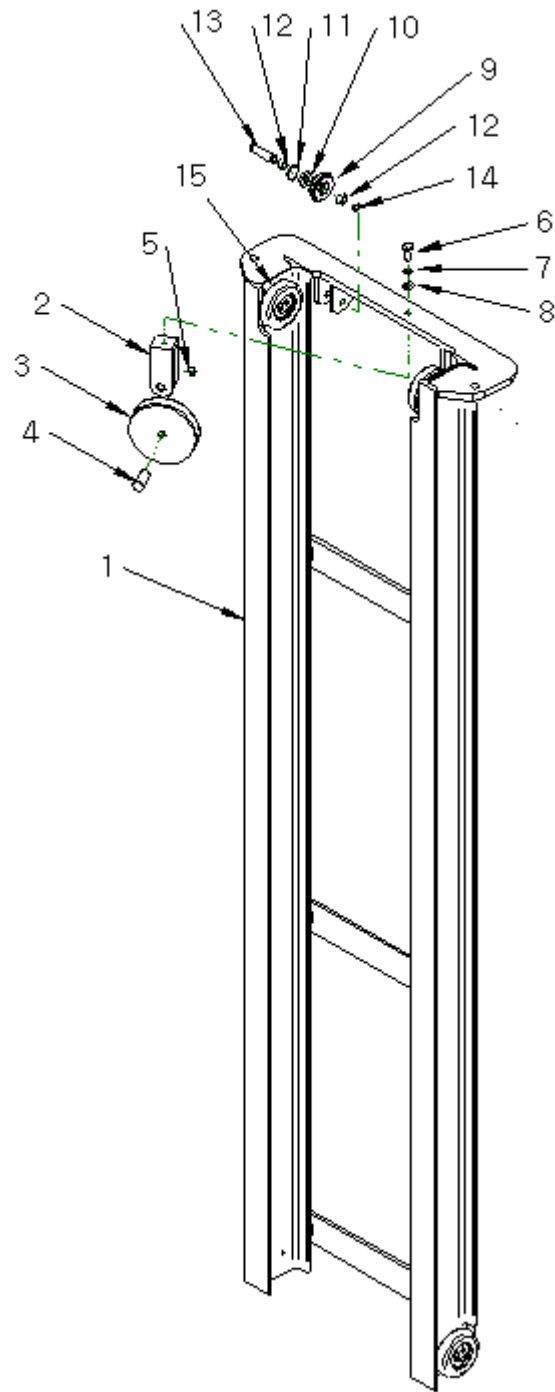

2) MIDDLE MAST

NO.	パーツNo.	名 称	Q'TY	備 考
1	MA-411	MIDDLE MAST	1	工場修理対象部品
2	MA-BK01	HOSE ROLLER BRACKT	1	
3	HDR-001	HOSE ROLLER	1	
4	HDP-002	PIN	1	
5	SN-S02	SNAP RING	1	
6	BT-M12	BOLT	1	
7	PW-M12	PLAN WASHER	1	
8	SW-M12	SPRING WASHER	1	
9	CHA-R601	CHAIN ROLLER	2	
10	BR-002	BEARING	2	
11	SN-03	SNAP RING	2	
12	-	BUSH	4	
13	CHA-P601	CHAIN ROLLER PIN	2	
14	SN-S04	SNAP RING	2	
15	MA-R601	MAST ROLLER ASS'Y	4	

3) OUT MAST

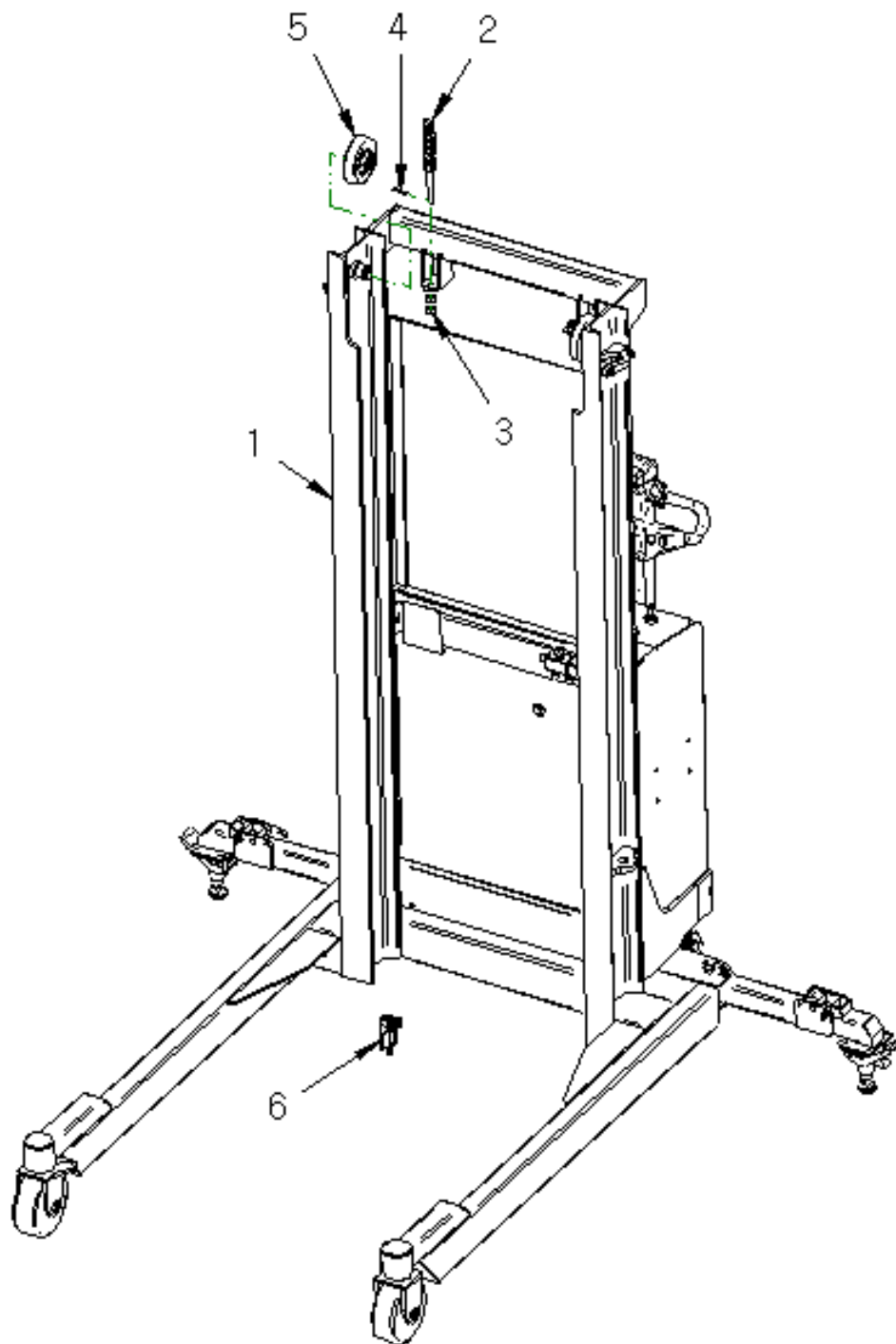

3) OUT MAST

NO.	パーツNo.	名 称	Q'TY	備 考
1	BD-401	BODY FRAME	1	工場修理対象部品
2	CHA-002	MAST CHAIN ASS'Y	2	
3	-	R-PIN	4	
4	NT-M12	NUT	8	
5	MA-R601	MAST ROLLER ASS'Y	2	
6	EL-LT01	LIMIT SWITCH	1	

FORK PART (APL-500-4M)

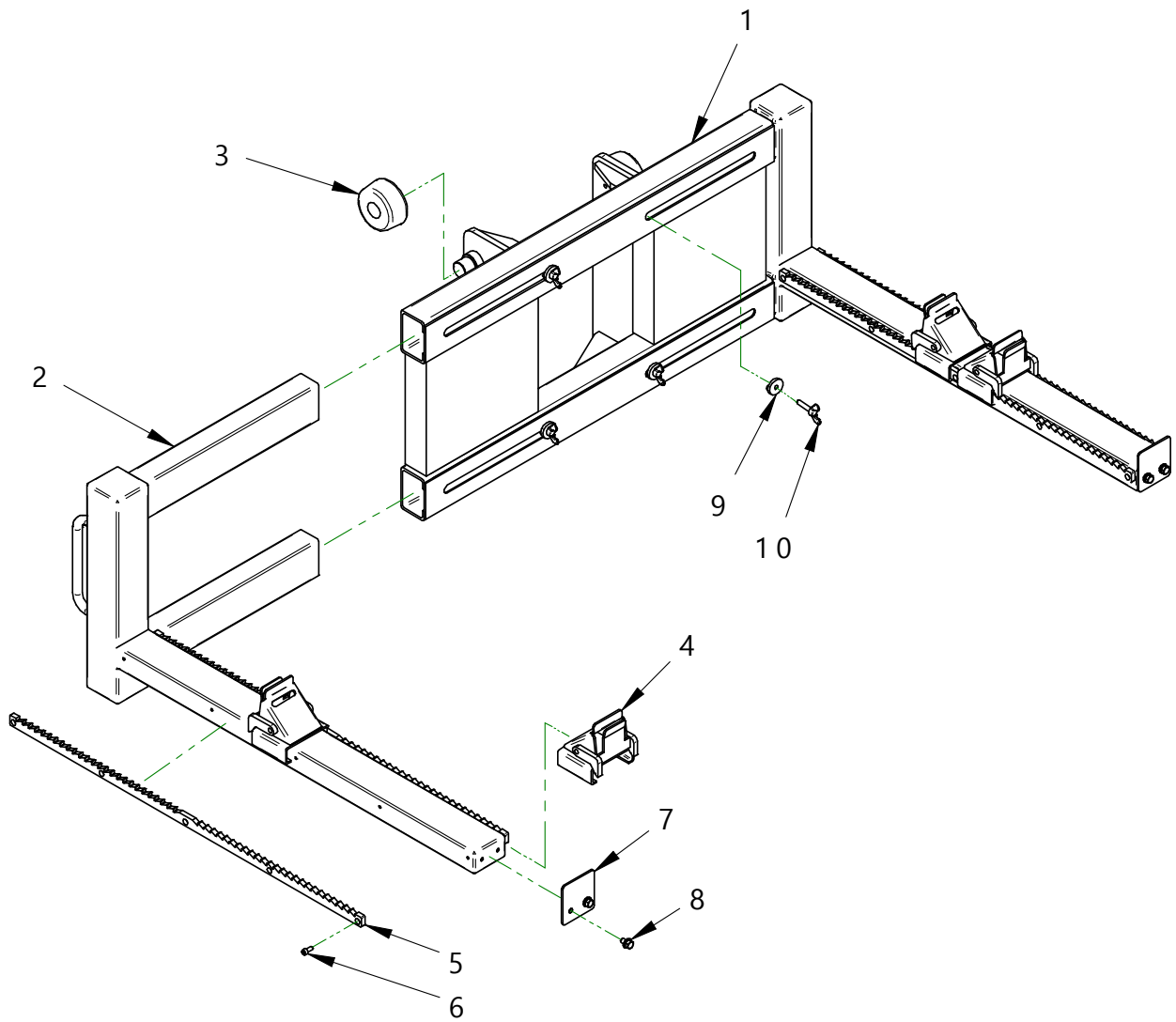

FORK PART (APL-500-4M)

ITEM NO.	PART NUMBER	DESCRIPTION	Q'TY	REMARKS
1	FK-001	FORK HOUSE	1	
2	FK-F01	FORK(850)	2	850mm 片面仕様
3	MA-R01	MAST & FORK ROLLER	4	
4	FK-B02	PIPE STOPPER	4	
5	FK-B01	RATCHET ROD	4	
6	SHBT-M6	BOLT	20	
7	FK-F001	FORK STOPPER	2	
8	SBT-M8	SEMS BOLT	4	
9	FK-WS01	WING WASHER	4	
10	WBT-M10	WING BOLT	4	
11				
12				
13				
14				
15				
16				
17				
18				
19				
20				

FORK PART (SLIDE FORK TYPE)

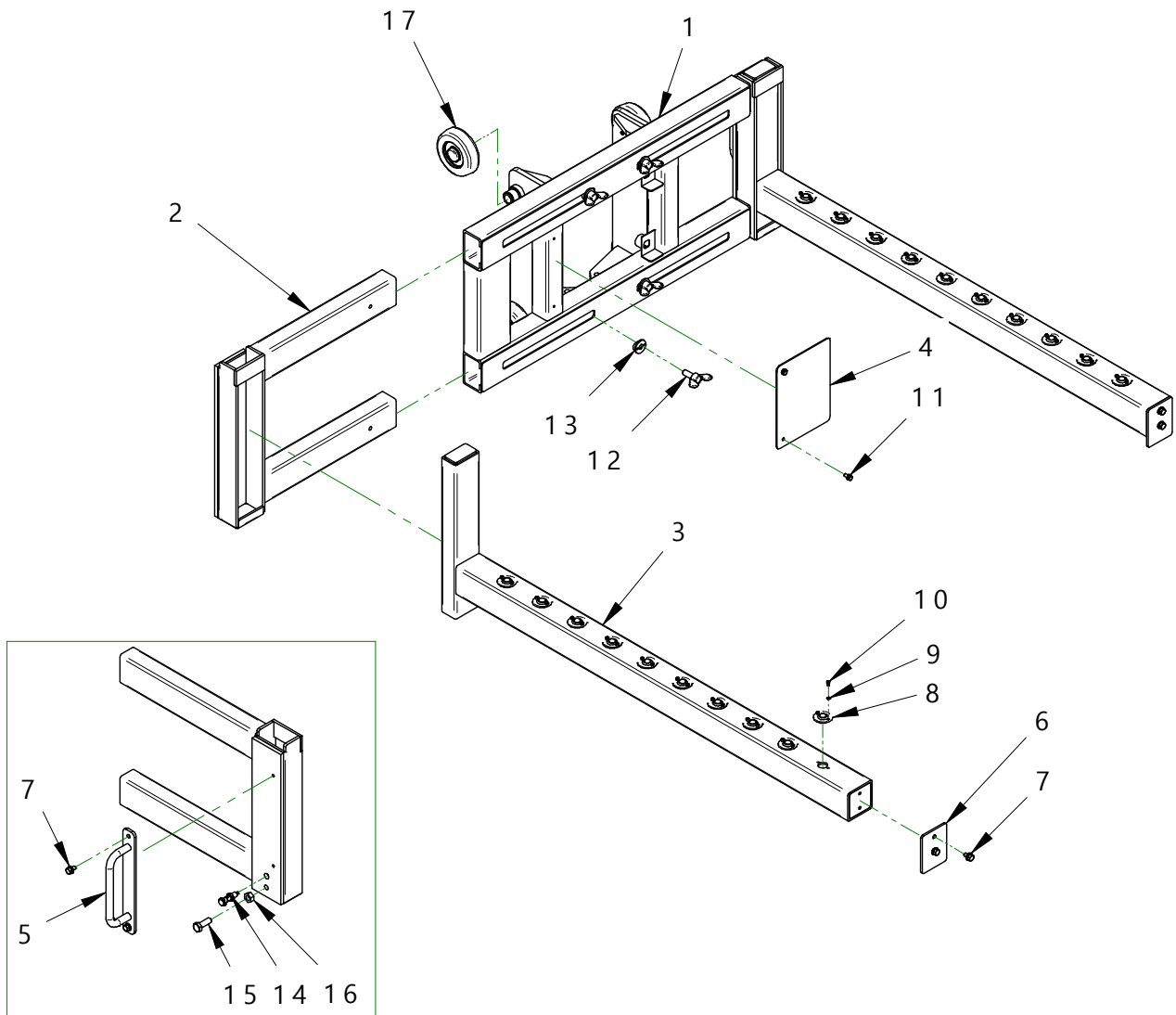

FORK PART (SLIDE FORK TYPE)

NO.	パーツNo.	名 称	Q'TY	備 考
1	FK-602	FORK HOUSE	1	FORK HOUSE と FORK BASE は組み合 わせにて販売
2	FK-SF01	FORK BASE	2	
3	FK-SF02	FORK	2	
4	FK-603	FORK PLATE	1	
5	FK-SFH	HANDLE	2	
6	FK-F6002	FORK STOPER	2	
7	SBT-M8	SEMS BOLT	8	
8	FK-BC	BALL CASTER	40	
9	SW-M4	SPRING WASHER	80	
10	SHBT-M4	BOLT	80	
11	SBT-M6	SEMS BOLT	2	
12	WBT-M10	WING BOLT	4	
13	FK-WS01	WING WASHER	4	
14	SHBT-M6	INDEX PLUNGER	2	
15	BT-M12	BOLT	2	
16	NT-M12	NUT	2	
17	MA-R601	MAST ROLLER ASS'Y	4	

SLIDE FORK PART (SLIDE FORK TYPE)

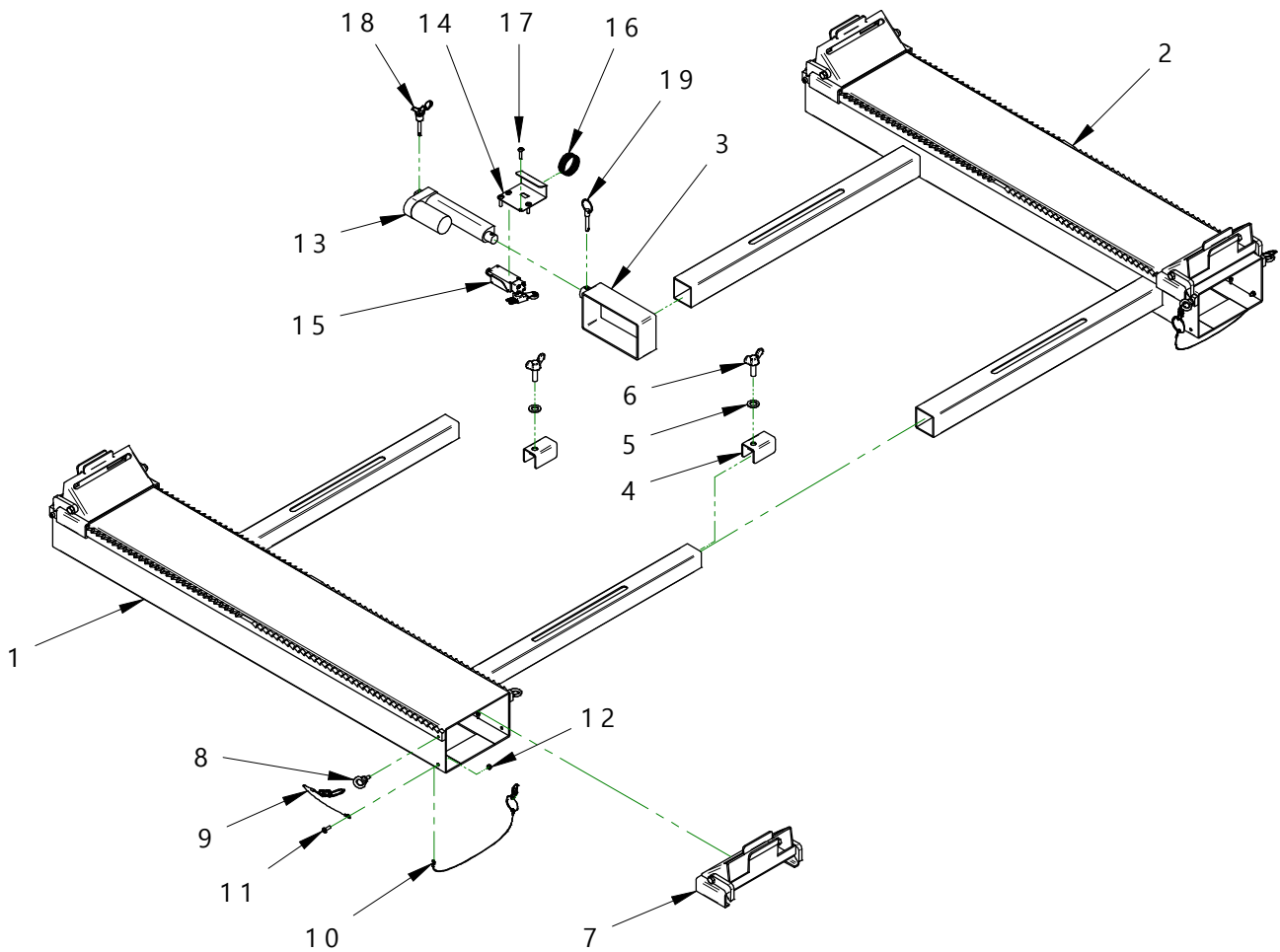

FORK PART (SLIDE FORK TYPE)

NO.	パーツNo.	名 称	Q'TY	備 考
1	FK-SFRH	SLIDE FORK(RH)	1	
2	FK-SFLH	SLIDE FORK(LH)	1	
3	FK-SFB01	LOCK BRACKET	1	
4	FK-SFB02	SLIDE LOCK BRACKET	2	
5	PW-M10	PLAN WASHER	2	
6	WBT-M10	WING BOLT	2	
7	FK-B03	PIPE STOPER	4	
8	IBT-M6	EYEBOLT	4	
9	WR-01	WIRE ASS'Y	2	
10	WR-02	WIRE ASS'Y	2	
11	BT-M5	BOLT	2	
12	NT-M5	NUT	2	
13	EL-CY01	LOCK CYLINDER	1	
14	EL-LTBK	LIMIT BRACKET	1	
15	EL-LT01	LIMIT SWITCH	1	
16	EL-LTBKR	RING	1	
17	BT-M5	BOLT	4	
18	BLP01	LOCK PIN	1	
19	BLP02	LOCK PIN	1	