

Electric Scissors Lift <SSL-1932N>

as at : 04/2017

Parts Catalog

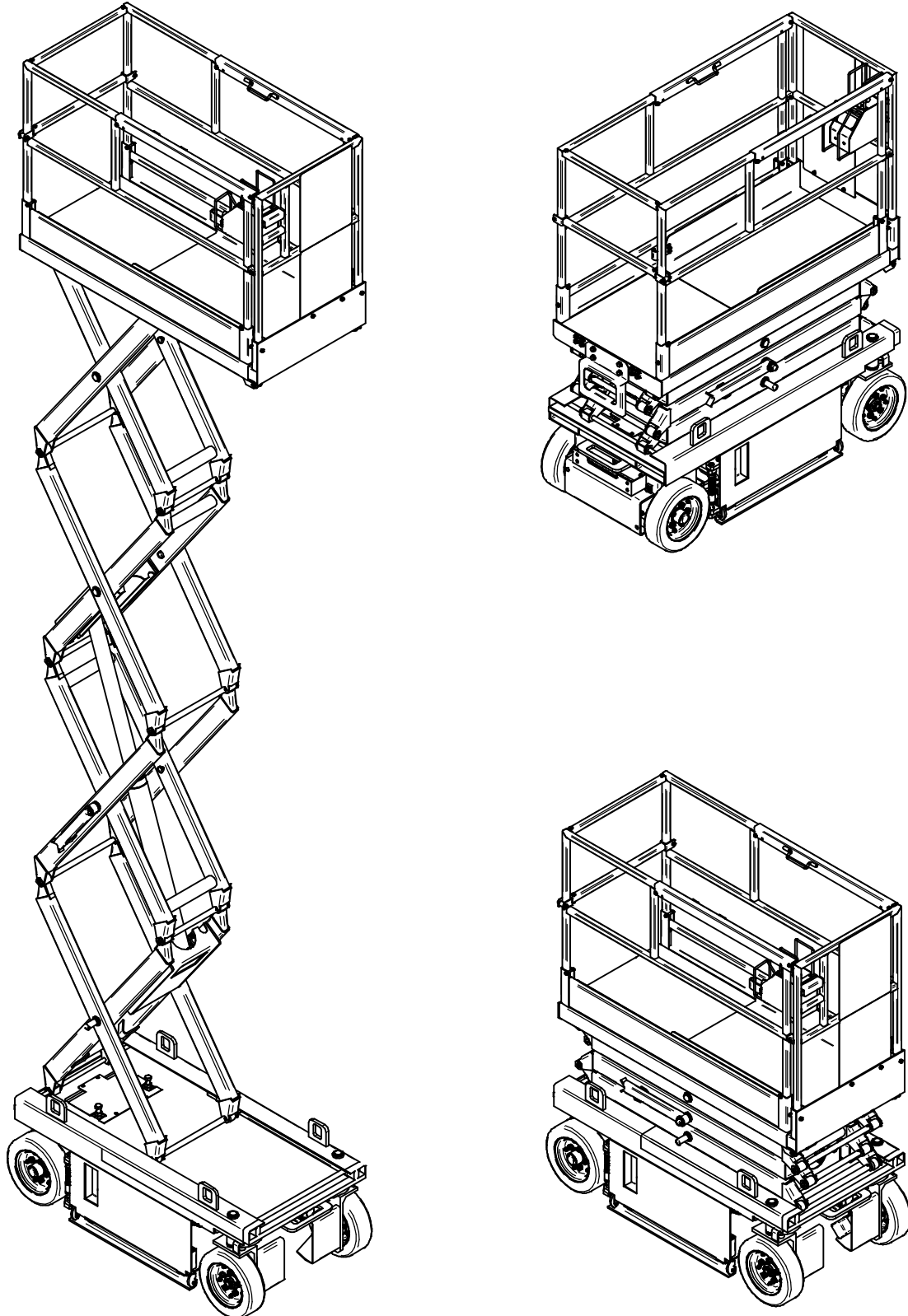

Electric Scissors Lift <SSL-1932N>

as at : 04/2017

TABLE OF CONTENTS <1/2>

SECTION 1 General Information

Major Assembly	1-1
----------------	-----

SECTION 2 Platform Assemblies

Platform Assembly	2-1
Platform	2-2
Extention Platform	2-3
Sliding Roller Assembly	2-4
Sliding Frame	2-5
Door	2-6
Joy Stick Box	2-7

SECTION 3 Scissors Arm Frame Assemblies

Scissors Arm Frame Assembly	3-1
Lift Cylinder Assembly	3-2

Electric Scissors Lift <SSL-1932N>

as at : 04/2017

TABLE OF CONTENTS <2/2>**SECTION 4 Lower Frame Assemblies**

Lower Frame Assembly	4-1
Lower Frame	4-2
Wheel House Assembly	4-3
Tire Assembly	4-4
Unit Box Assembly	4-5
Battery Box Assembly	4-6
Stabillazer	4-7
Box Stopper	4-8
Steering System	4-9
Steering Cylinder Assembly	4-10
Drive Wheel Assembly	4-11
Brake Cylinder Assembly	4-12
Safety Stopper Assembly	4-13
Stopper Link	4-14

SECTION 5 Hydraulic & Electric System

Platform Accessories	5-1
Joy Stick Box Component	5-2
Control Panel Component	5-3
Unit Box Component	5-4
Hydraulic Block Assembly	5-5
Hydraulic Motor Component	5-6
Battery Box Component	5-7

Electric Scissors Lift <SSL-1932N>

as at : 04/2017

Electric Scissors Lift <SSL-1932N>

as at : 04/2017

SECTION 1 General Information

Major Assembly

1-1

Electric Scissors Lift <SSL-1932N>

as at : 04/2017

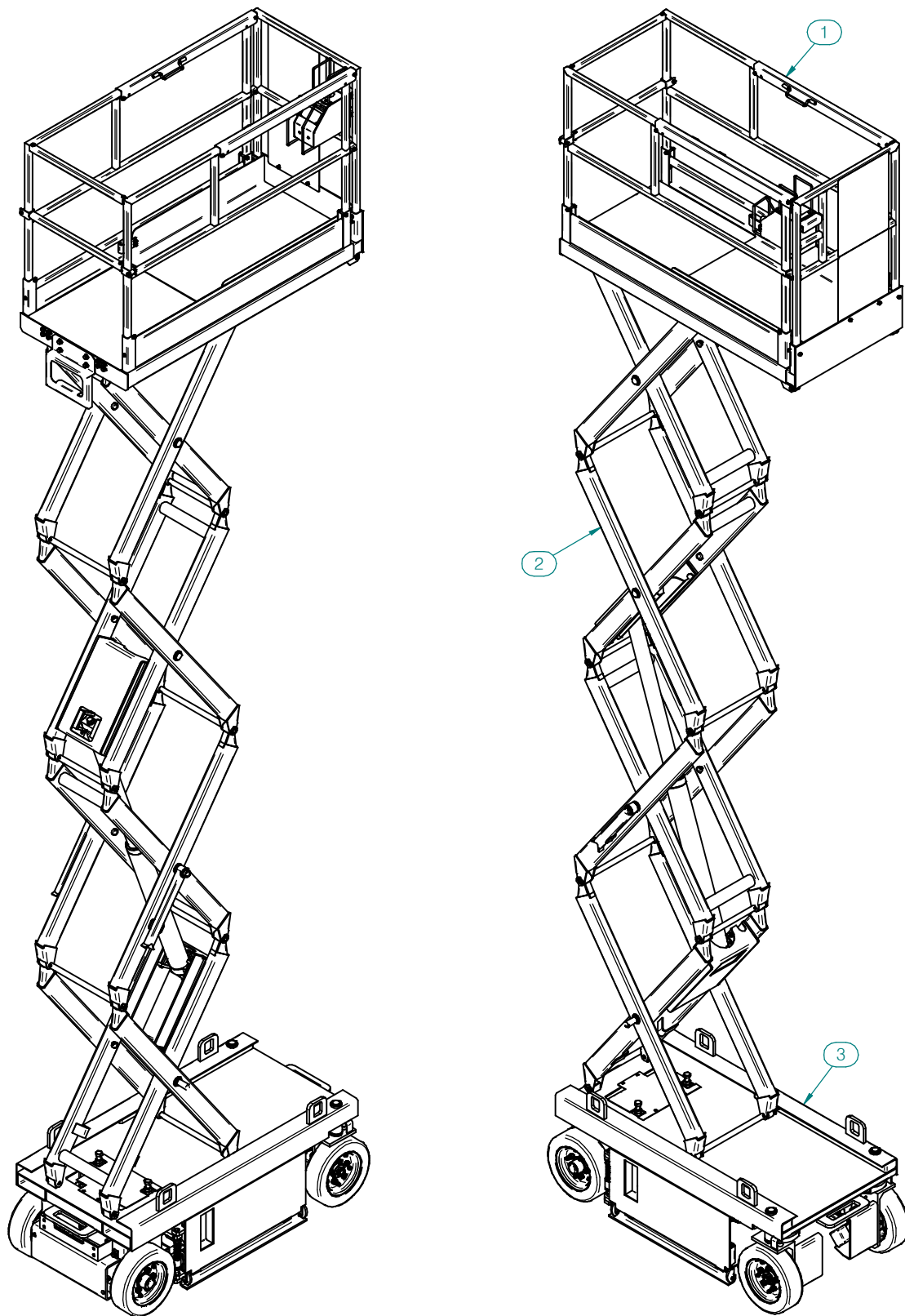

Electric Scissors Lift <SSL-1932N>

as at : 04/2017

Electric Scissors Lift <SSL-1932N>

as at : 04/2017

SECTION 2 Platform Assemblies

Platfrom Assembly	2-1
Platfrom	2-2
Extention Platform	2-3
Sliding Roller Assembly	2-4
Sliding Frame	2-5
Door	2-6
Joy Stick Box	2-7
Sliding Frame	2-5
Door	2-6
Joy Stick Box	2-7

Electric Scissors Lift <SSL-1932N>

as at : 04/2017

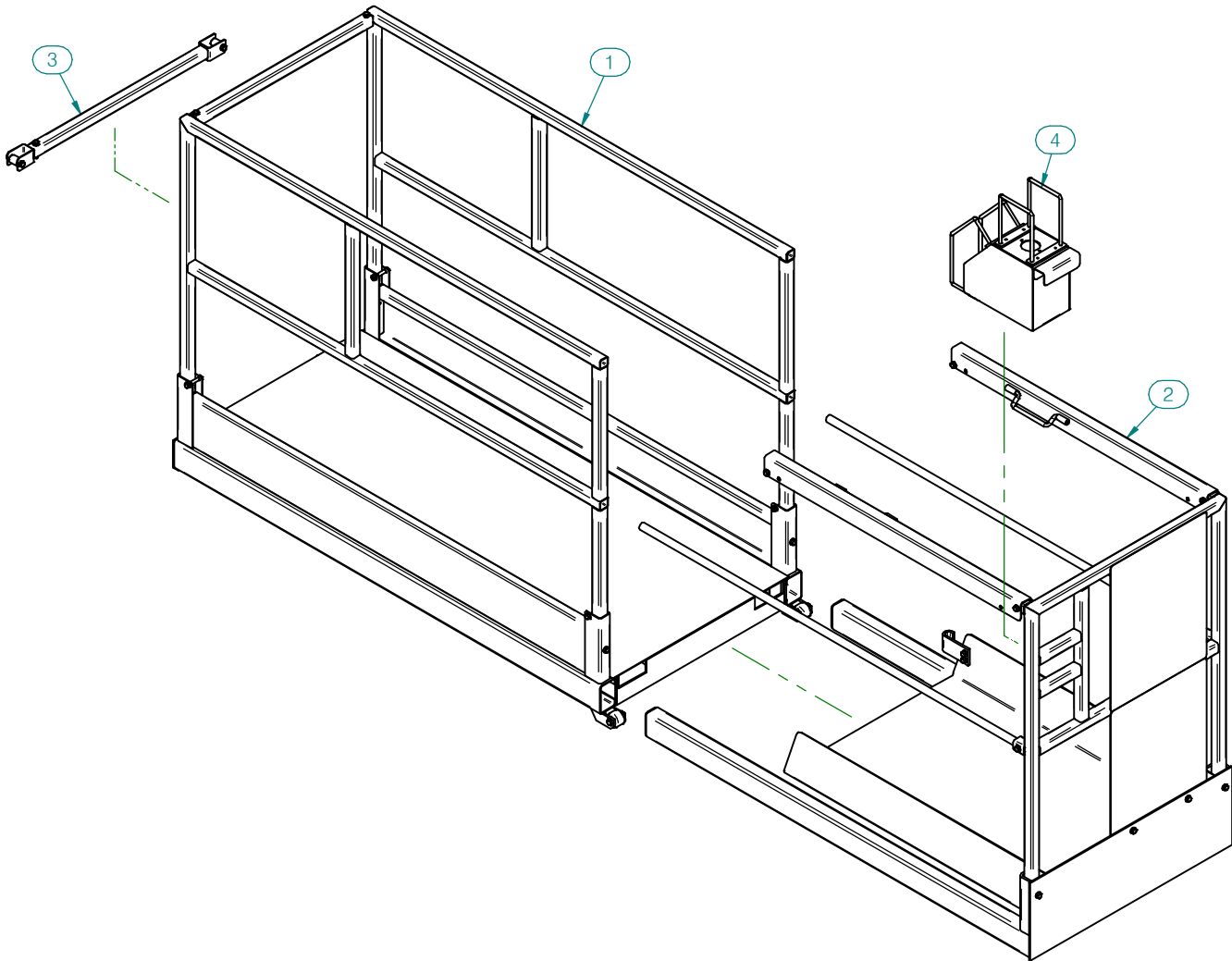

Electric Scissors Lift <SSL-1932N>

as at : 04/2017

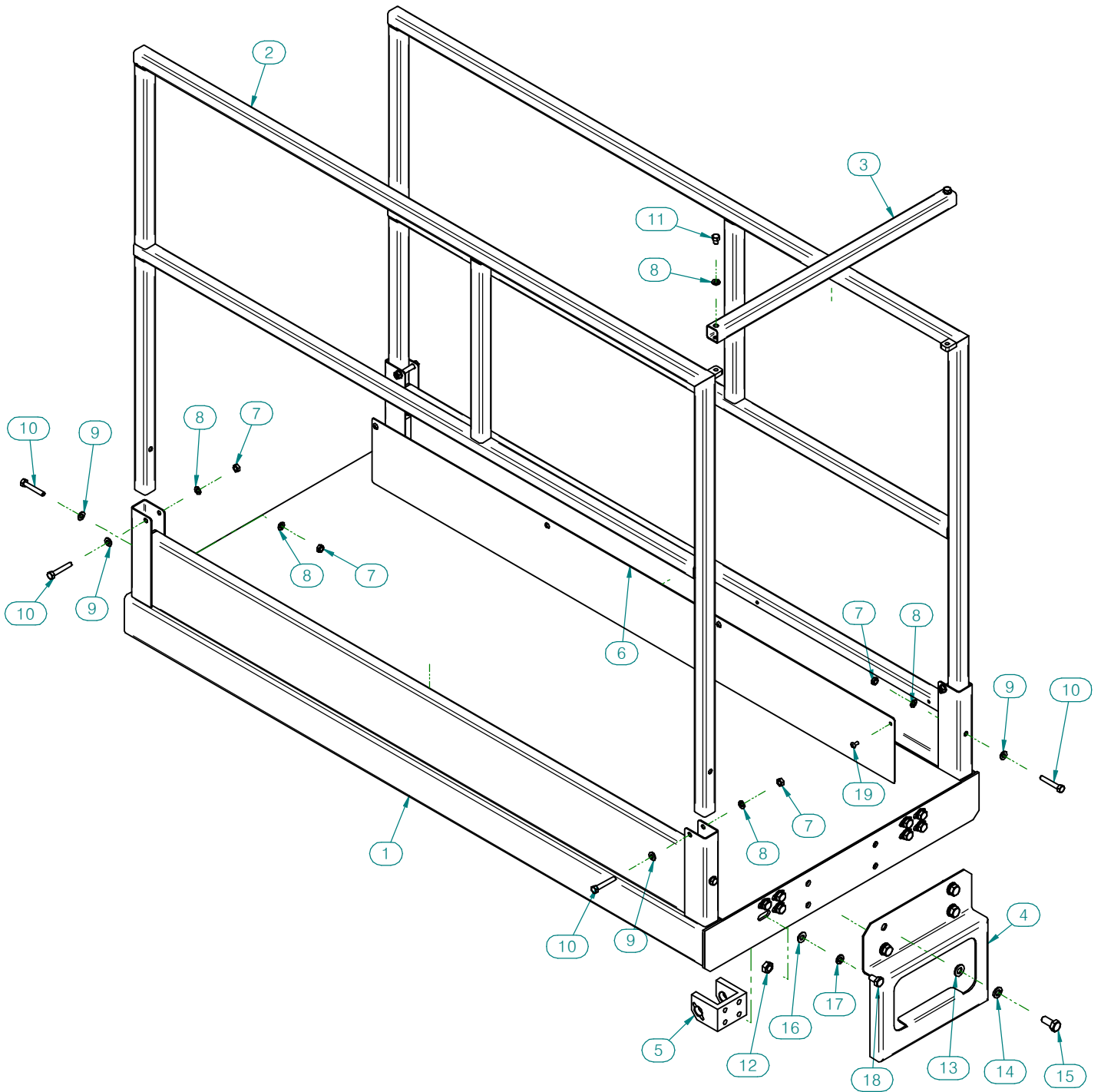

Electric Scissors Lift <SSL-1932N>

as at : 04/2017

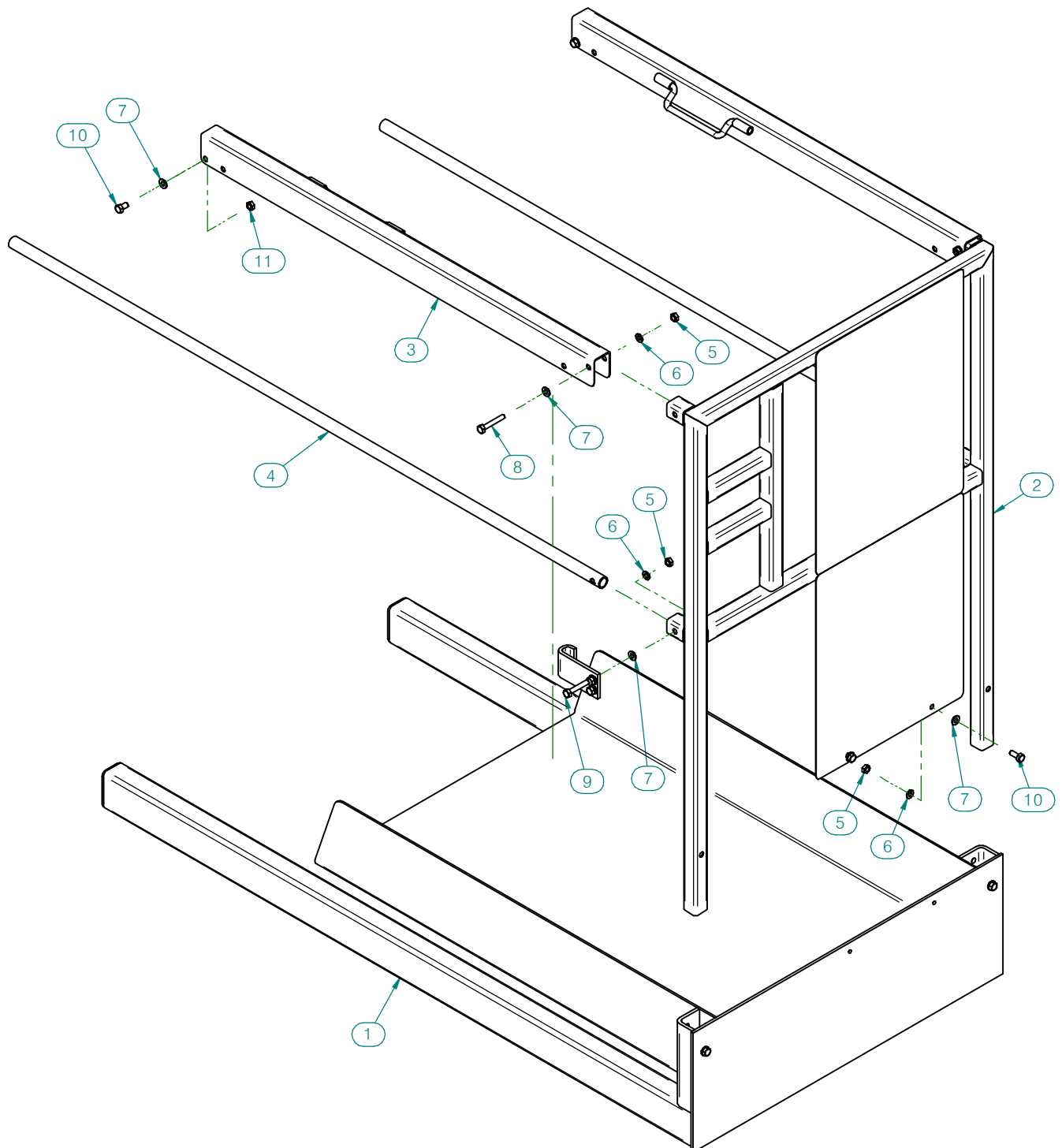

Electric Scissors Lift <SSL-1932N>

as at : 04/2017

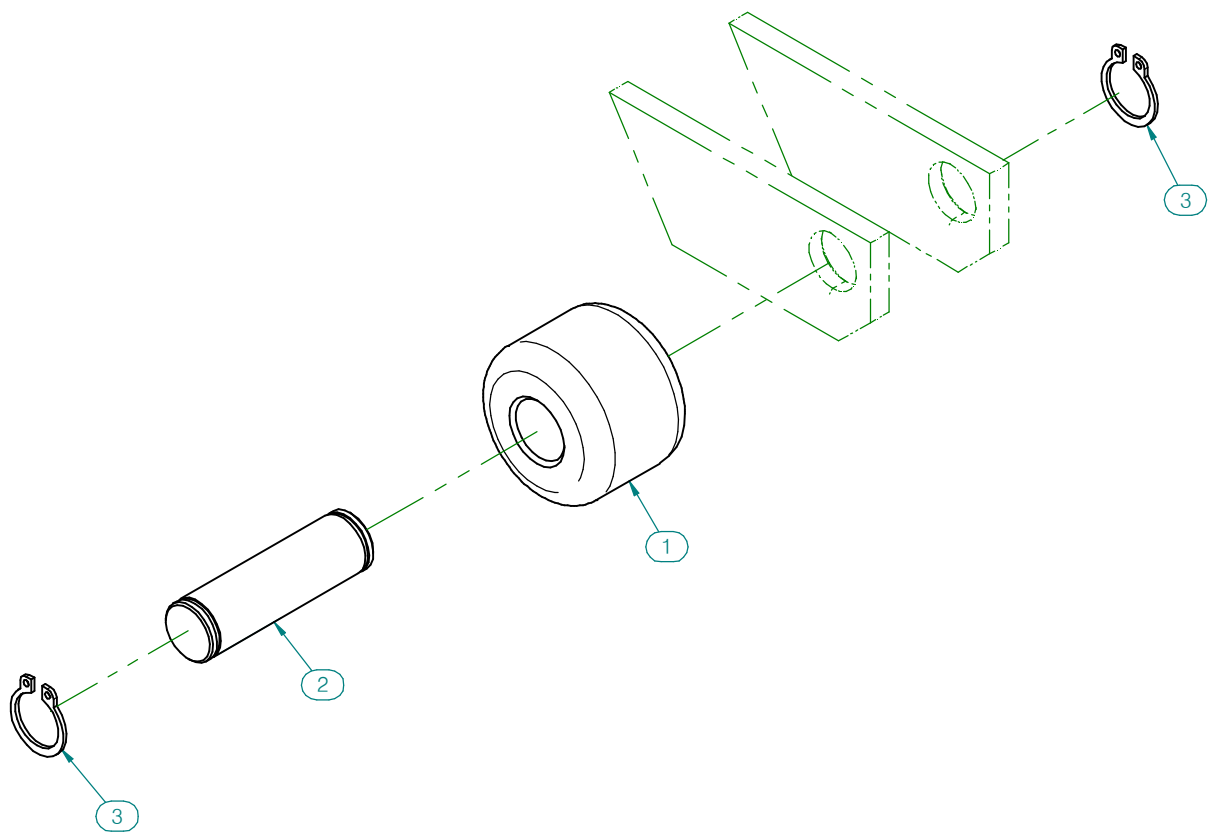

Electric Scissors Lift <SSL-1932N>

as at : 04/2017

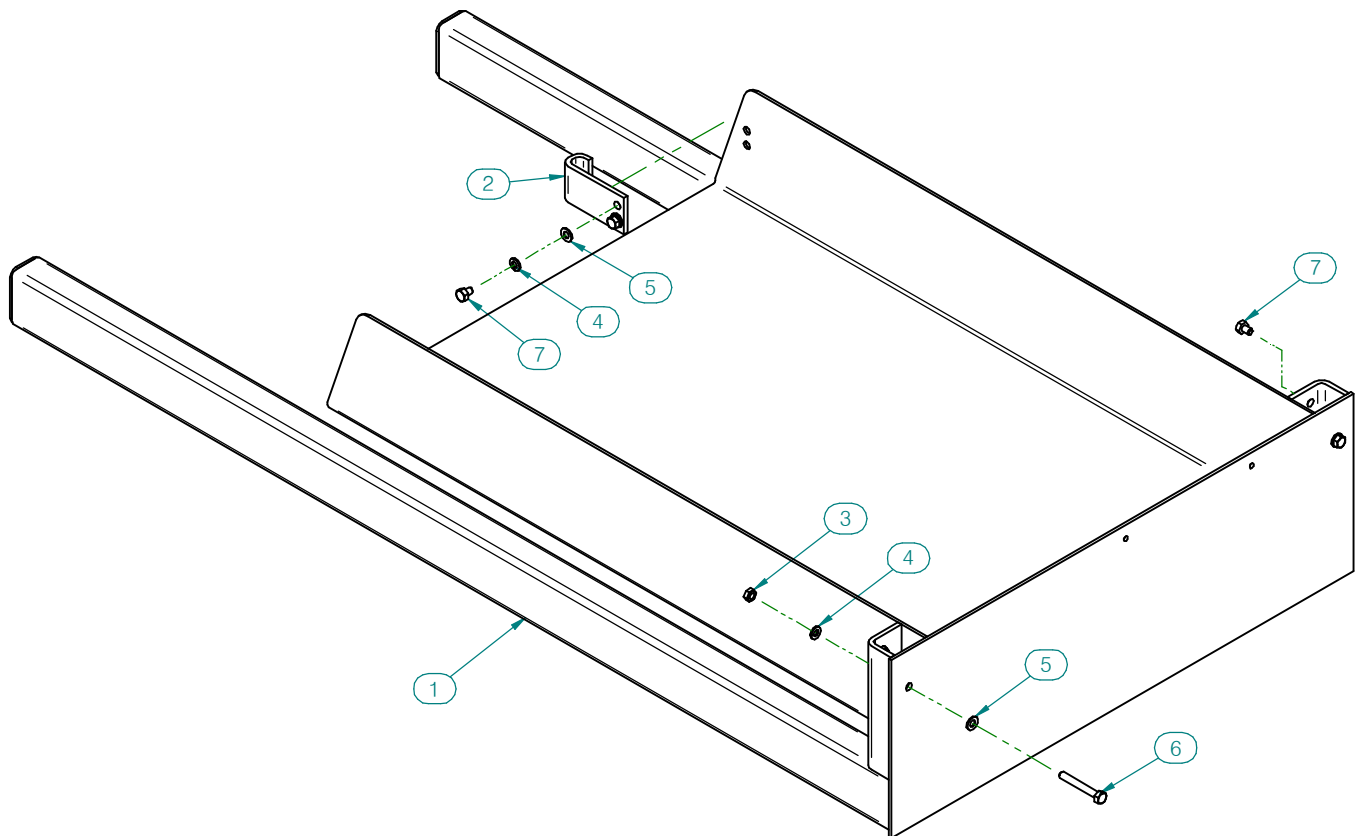

Electric Scissors Lift <SSL-1932N>

as at : 04/2017

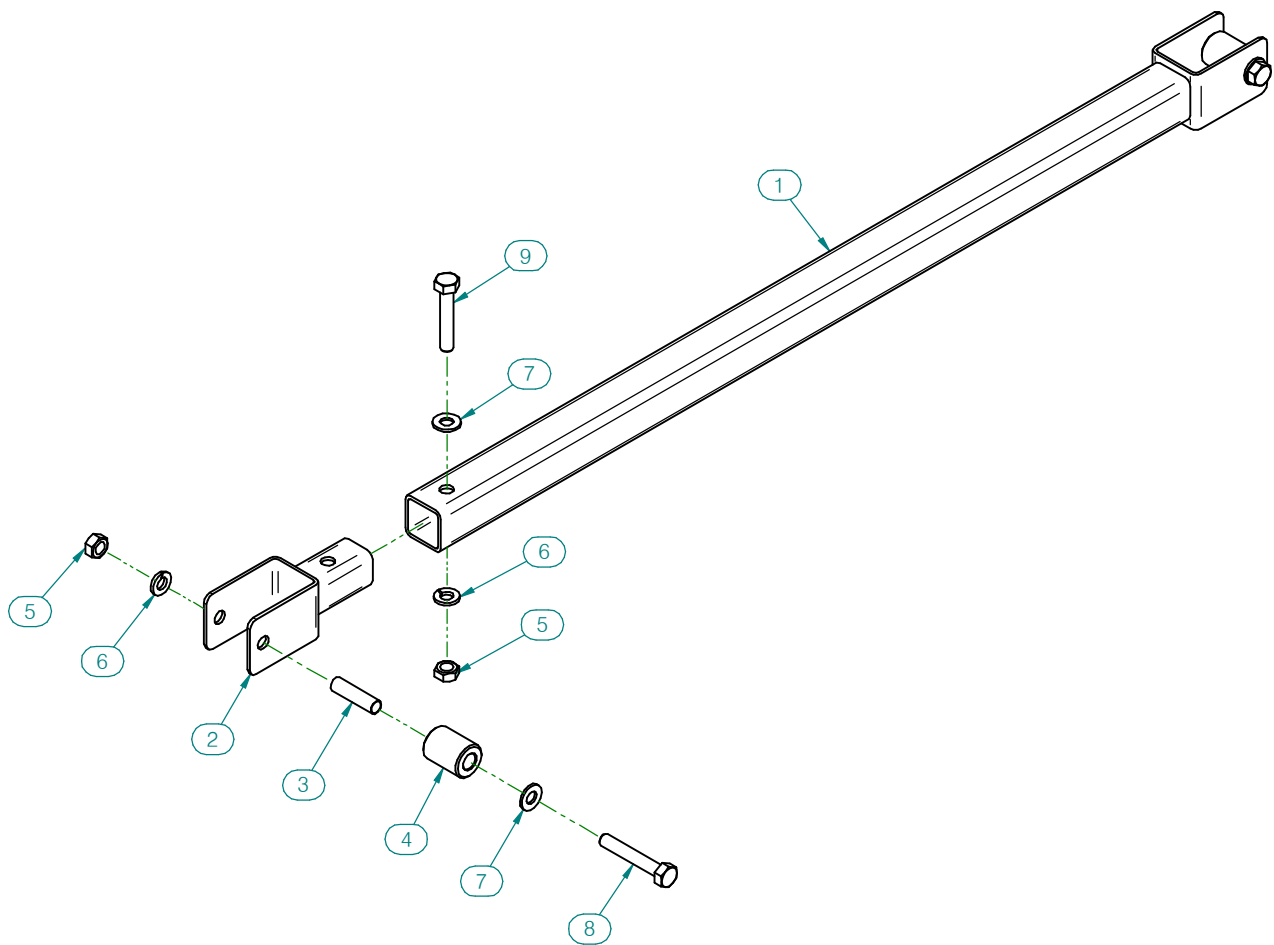

Electric Scissors Lift <SSL-1932N>

as at : 04/2017

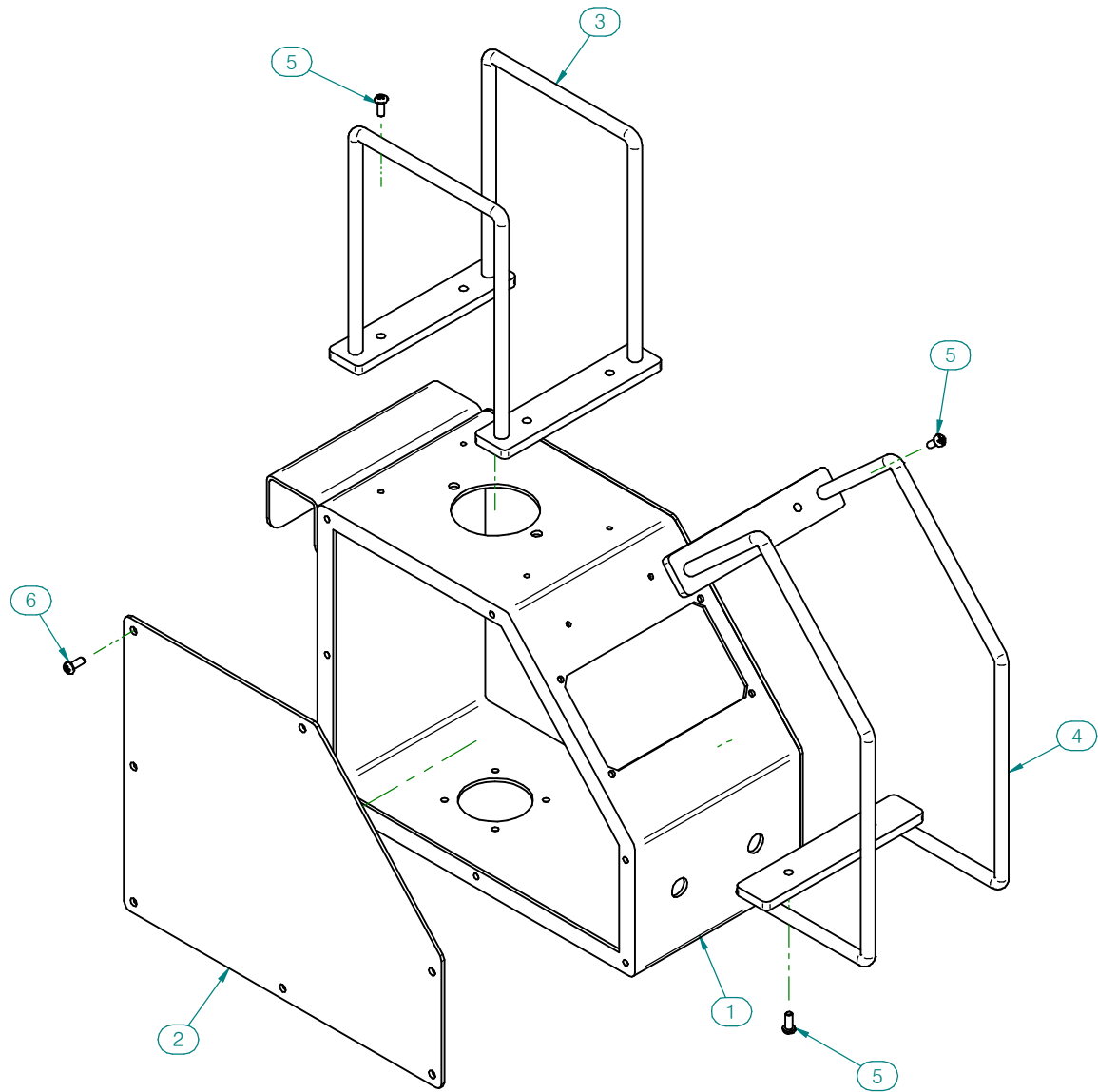

Electric Scissors Lift <SSL-1932N>

as at : 04/2017

Electric Scissors Lift <SSL-1932N>

as at : 04/2017

SECTION 3 Scissors Arm Frame Assemblies

Scissors Arm Frame Assembly	3-1
Lift Cylinder Assembly	3-2

Electric Scissors Lift <SSL-1932N>

as at : 04/2017

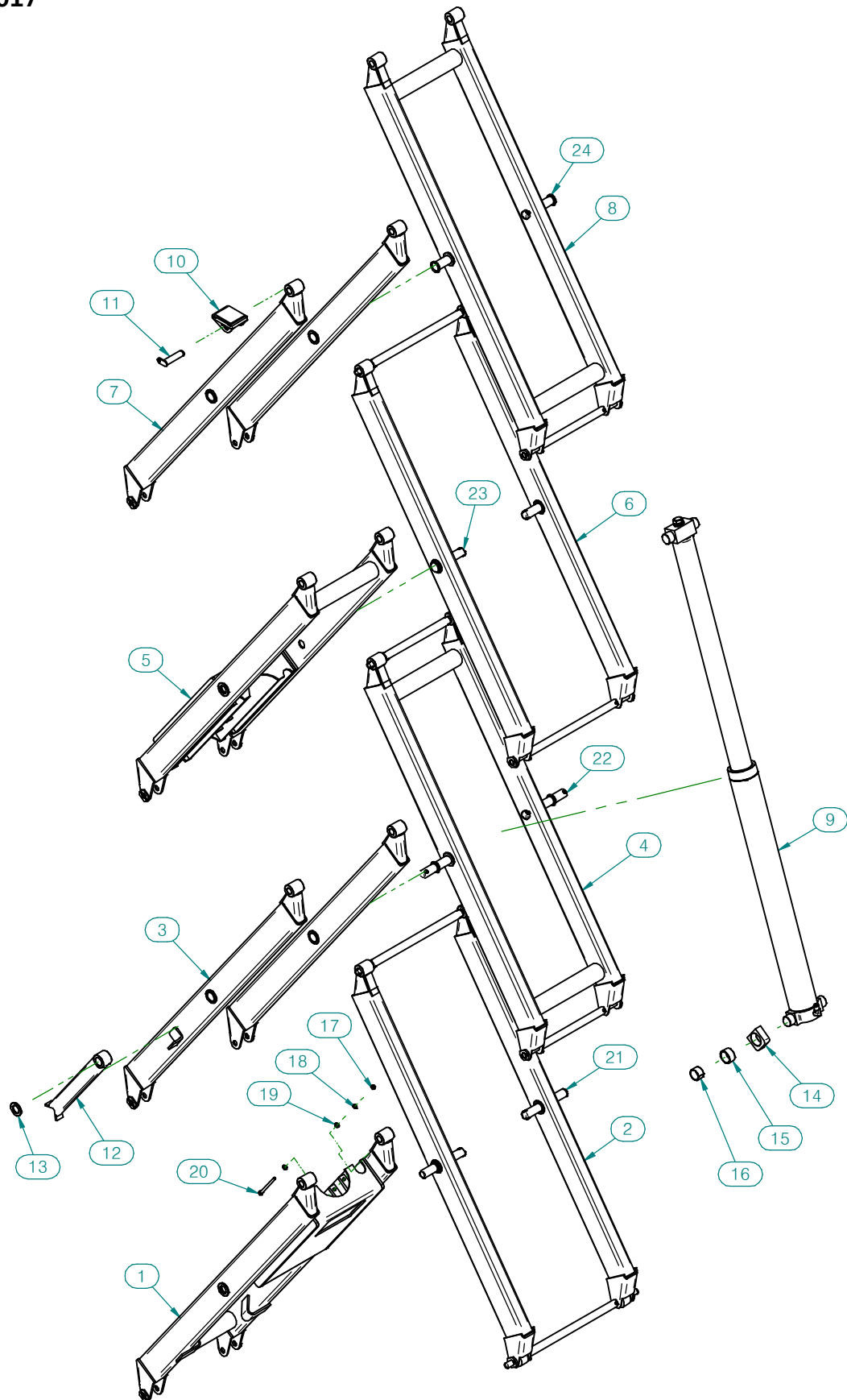

Electric Scissors Lift <SSL-1932N>

as at : 04/2017

FIGURE 3-01 ITEM NO.	PART NUMBER	DESCRIPTION	Q'TY	REMARKS
1	J002-1001-0100	1 STAGE INSIDE ARM	1	
2	J002-1001-0200	1 STAGE OUTSIDE ARM	1	
3	J002-1001-0300	2 STAGE OUTSIDE ARM	1	
4	J002-1001-0400	2 STAGE INSIDE ARM	1	
5	J002-1001-0500	3 STAGE INSIDE ARM	1	
6	J002-1001-0600	3 STAGE OUTSIDE ARM	1	
7	J002-1001-0700	4 STAGE OUTSIDE ARM	1	
8	J002-1001-0800	4 STAGE INSIDE ARM	1	
9	J002-1003-0100	LIFT CYLINDER ASSEMBLY	1	37SL-L750818
10	J002-1001-1000	UPPER FRAME SLIDING BRACKET	2	43SL-AM1920
11	J002-1001-1100	SLIDING BRACKET PIN	2	
12	J002-1001-1200	STOPPER	2	
13	J002-1001-1300	SPACER	2	
14	J002-1001-1400	LIFT CYLINDER BRACKET	2	
15	J002-1001-1500	SPACER	2	
16		DU BUSH	2	
17		NUT	4	
18		SPRING WASHER	4	
19		WASHER	8	
20		HEX BOLT	4	
21	J002-1001-2100	1 STAGE PIN	2	
22	J002-1001-2200	2 STAGE PIN	2	
23	J002-1001-2300	3 STAGE PIN	2	
24	J002-1001-2400	4 STAGE PIN	2	
	J002-1001-2500	HOSE SET	1	32HS-SL19

3-1 Scissors Arm Frame Assembly List

Electric Scissors Lift <SSL-1932N>

as at : 04/2017

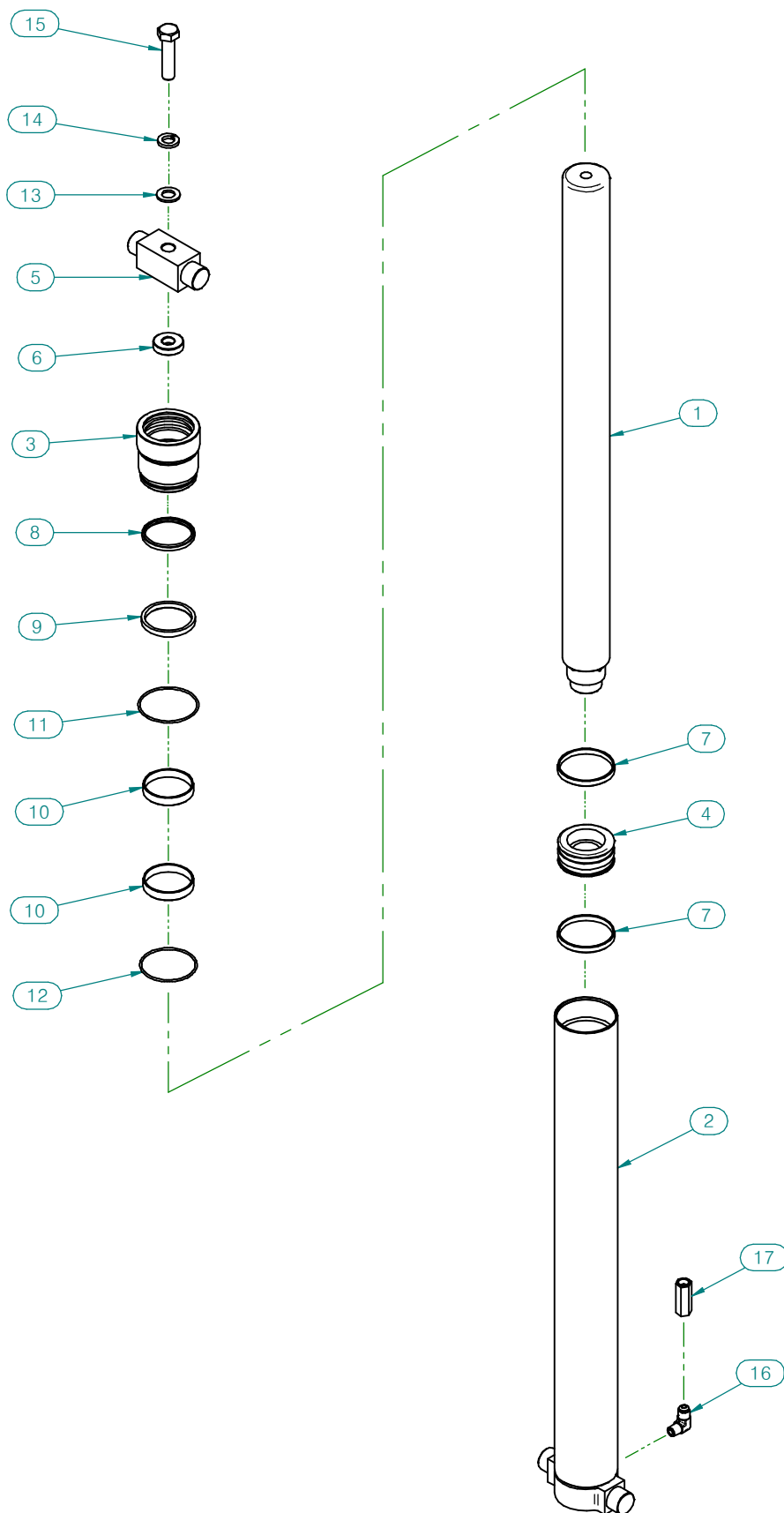

Electric Scissors Lift <SSL-1932N>

as at : 04/2017

Electric Scissors Lift <SSL-1932N>

as at : 04/2017

SECTION 4 Lower Frame Assemblies

Lower Frame Assembly	4-1
Lower Frame	4-2
Wheel House Assembly	4-3
Tire Assembly	4-4
Unit Box Assembly	4-5
Battery Box Assembly	4-6
Stabilizer	4-7
Box Stopper	4-8
Steering System	4-9
Steering Cylinder Assembly	4-10
Drive Wheel Assembly	4-11
Brake Cylinder Assembly	4-12
Safety Stopper Assembly	4-13
Stopper Link	4-14

Electric Scissors Lift <SSL-1932N>

as at : 04/2017

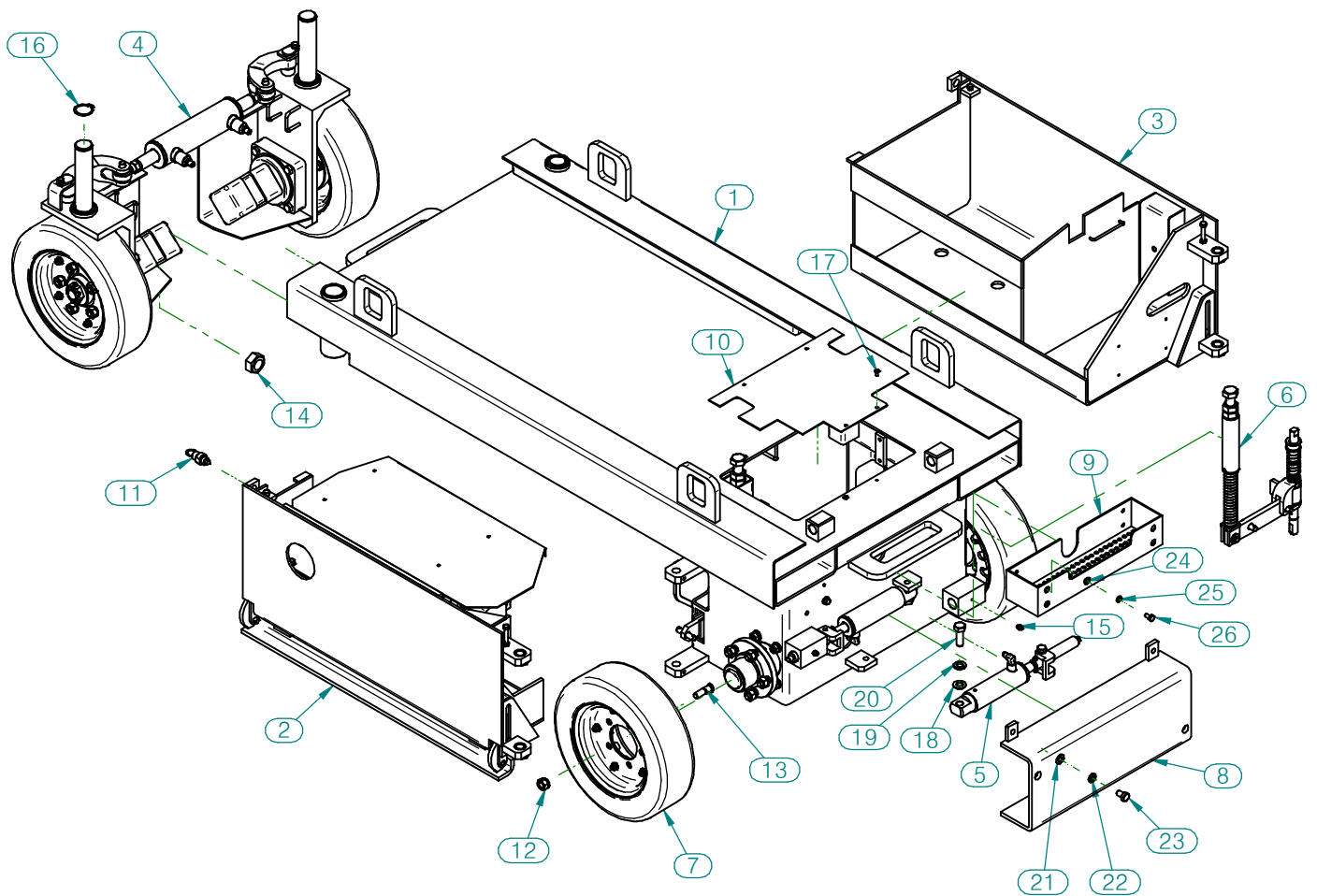

Electric Scissors Lift <SSL-1932N>

as at : 04/2017

FIGURE 4-01 ITEM NO.	PART NUMBER	DESCRIPTION	Q'TY	REMARKS
1	J002-1101-0100	LOWER FRAME	1	
2	J002-1101-0200	UNIT BOX	1	
3	J002-1101-0300	BATTERY BOX	1	
4	J002-1102-0100	STEERING SYSTEM	1	
5	J002-1104-0100	BRAKE CYLINDER	2	37SL-B40029
6	J002-1105-0100	STABILIZER	2	
7	J002-1107-0100	REAR WHEEL	2	
8	J002-1101-0800	BUMPER	1	
9	J002-1101-0900	CABLE BOX	1	
10	J002-1101-1000	COVER	1	
11	J002-1101-1100	BOX STOPPER	2	
12	J002-1101-1200	RIM NUT	10	
13	J002-1101-1300	RIM BOLT	10	
14	J002-1101-1400	STEERING NUT	4	
15		GREASE NIPPLE	2	
16		SNAP RING	2	
17		ROUND HEAD SCREW	4	
18		WASHER	2	
19		SPRING WASHER	2	
20		HEX BOLT	2	
21		WASHER	2	
22		SPRING WASHER	2	
23		HEX BOLT	2	
24		WASHER	4	
25		SPRING WASHER	4	
26		RENCH BOLT	4	

4-1 Lower Frame Assembly List

Electric Scissors Lift <SSL-1932N>

as at : 04/2017

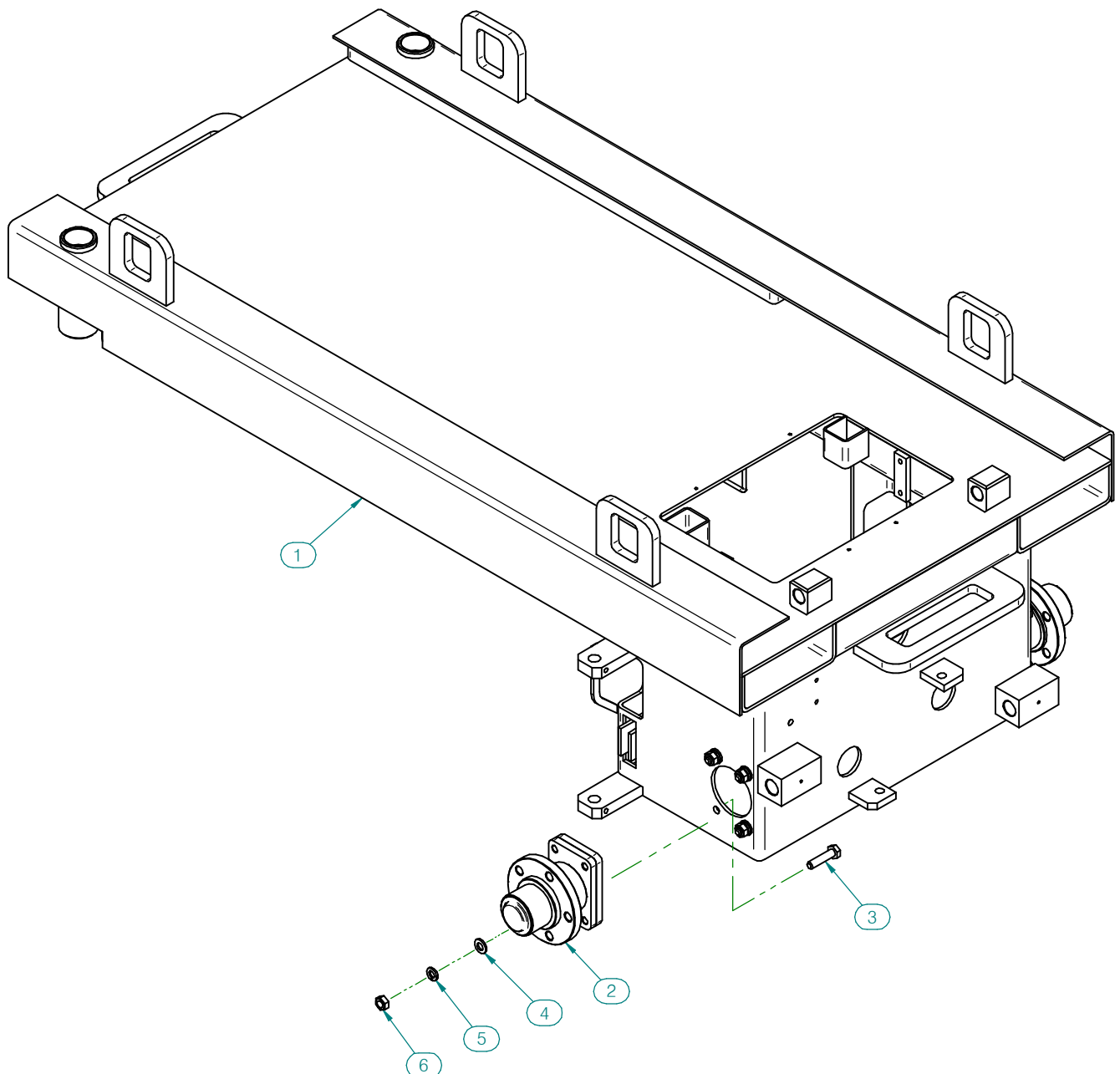

Electric Scissors Lift <SSL-1932N>

as at : 04/2017

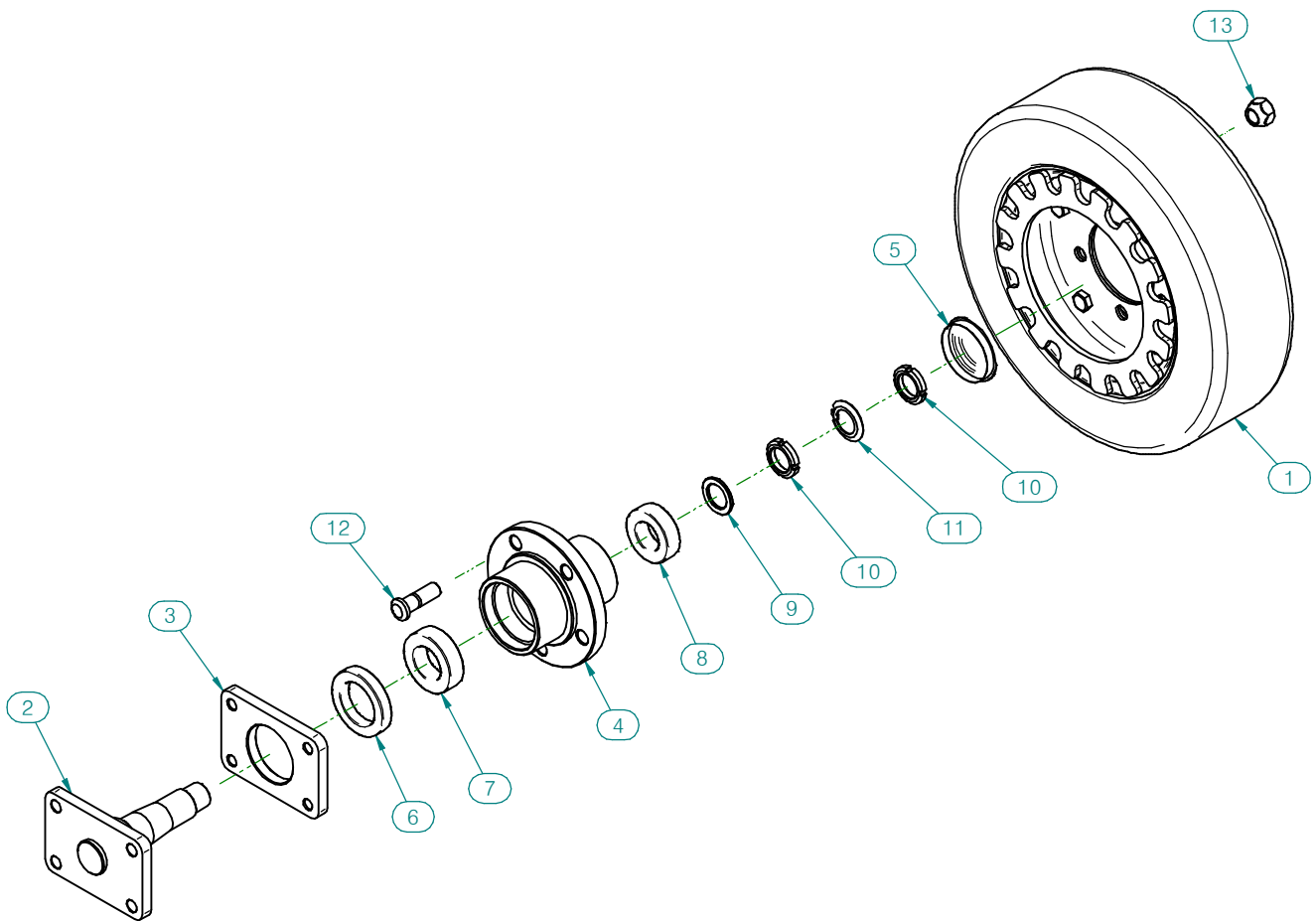

Electric Scissors Lift <SSL-1932N>

as at : 04/2017

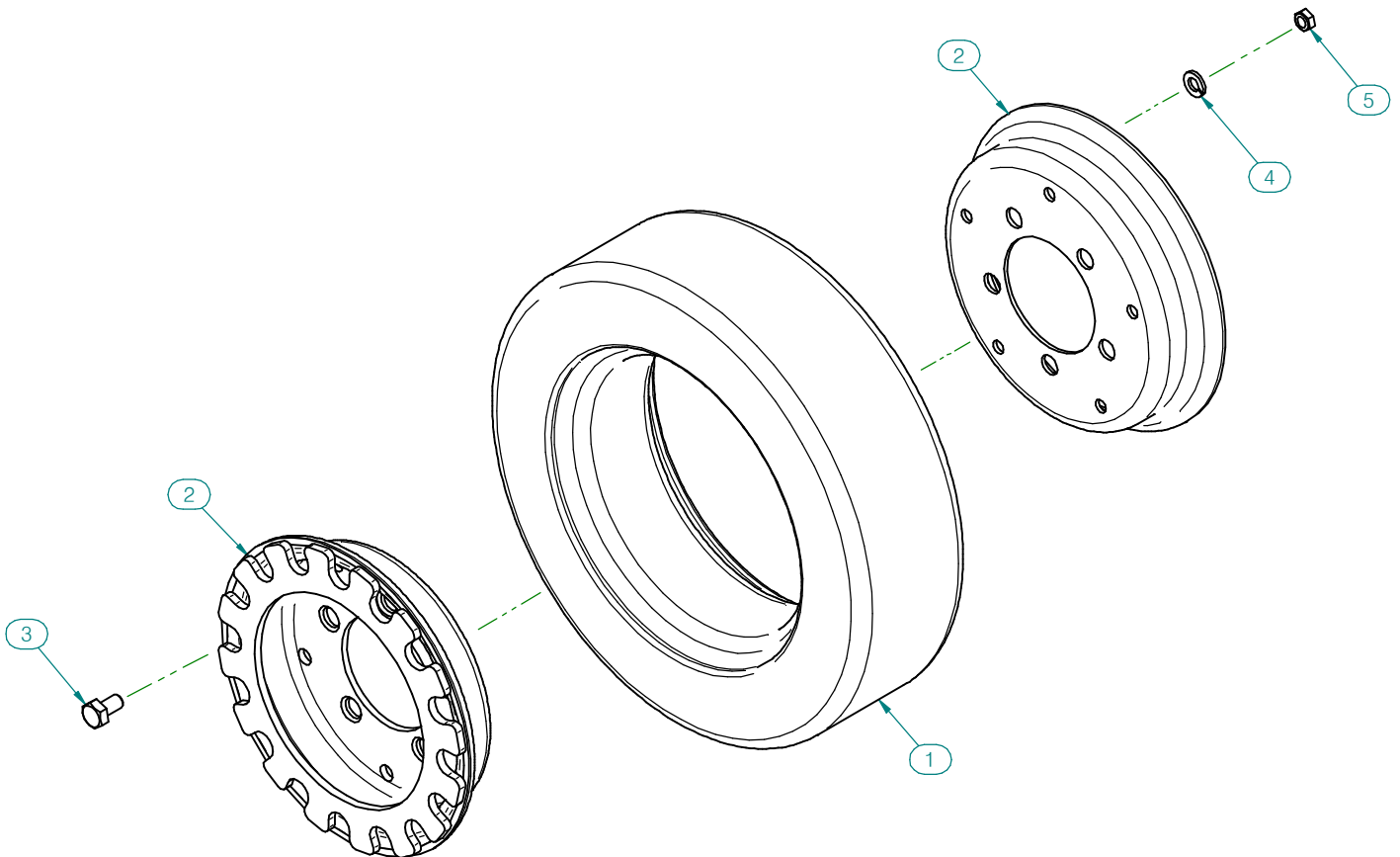

Electric Scissors Lift <SSL-1932N>

as at : 04/2017

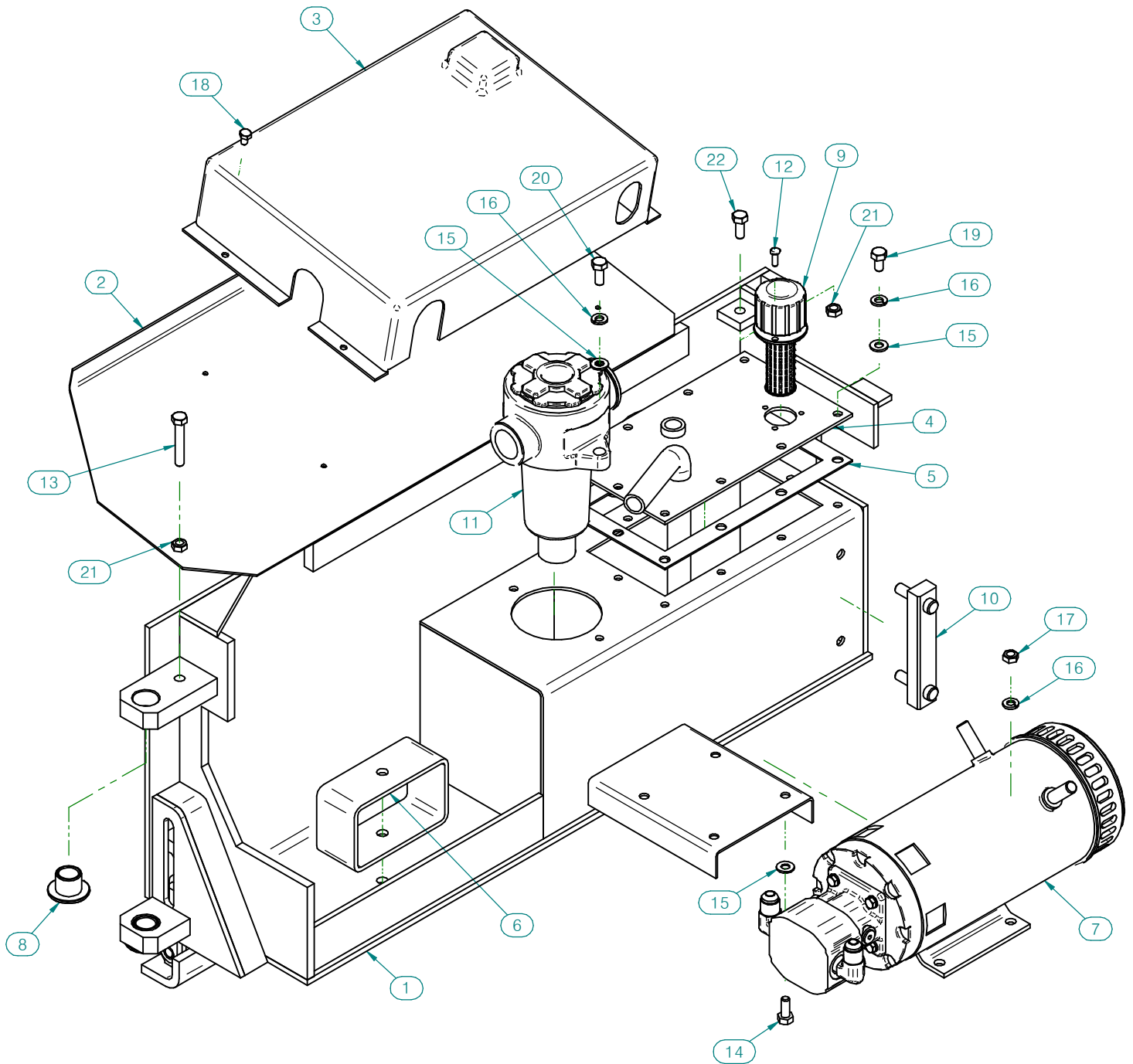

Electric Scissors Lift <SSL-1932N>

as at : 04/2017

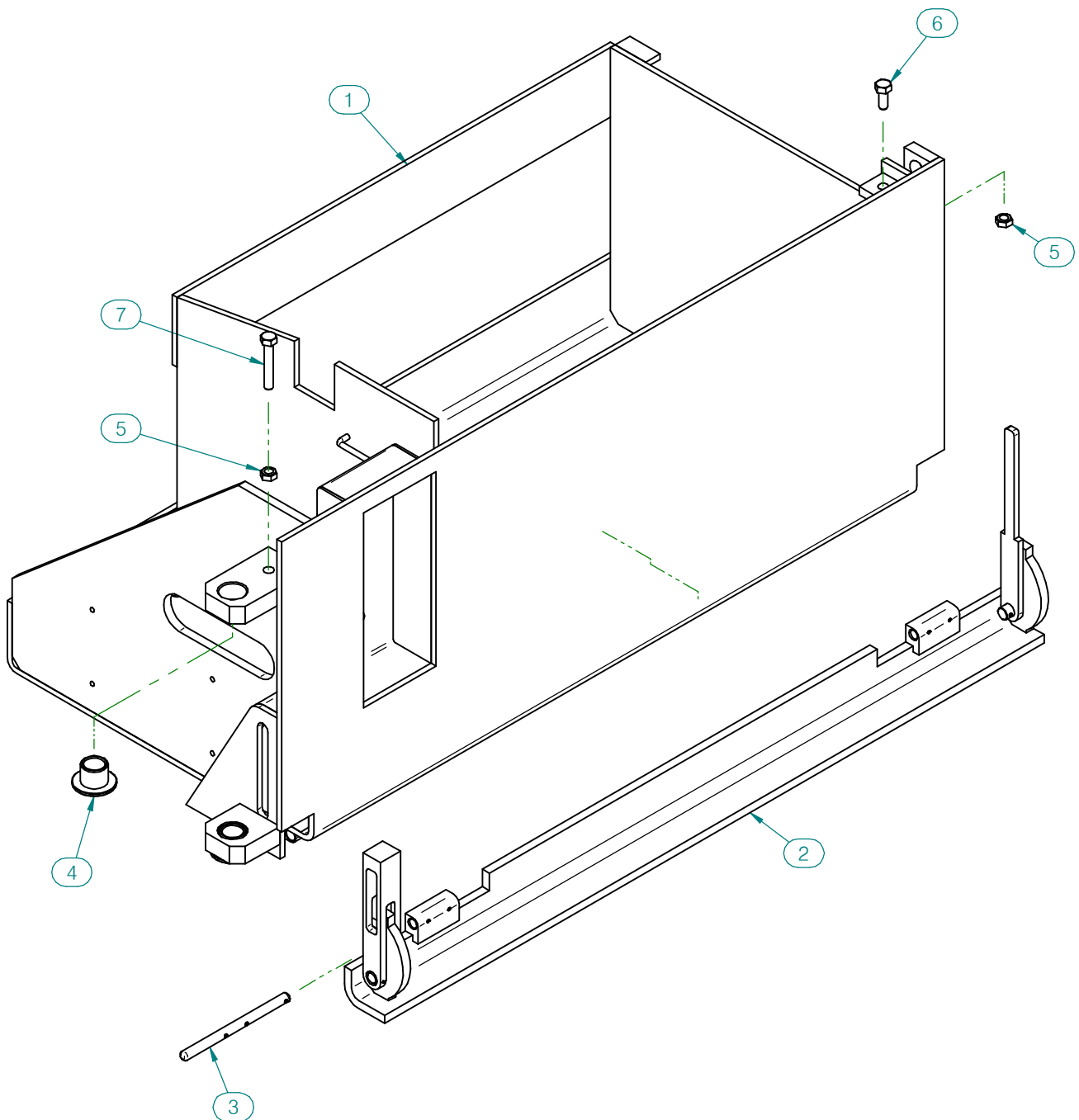

Electric Scissors Lift <SSL-1932N>

as at : 04/2017

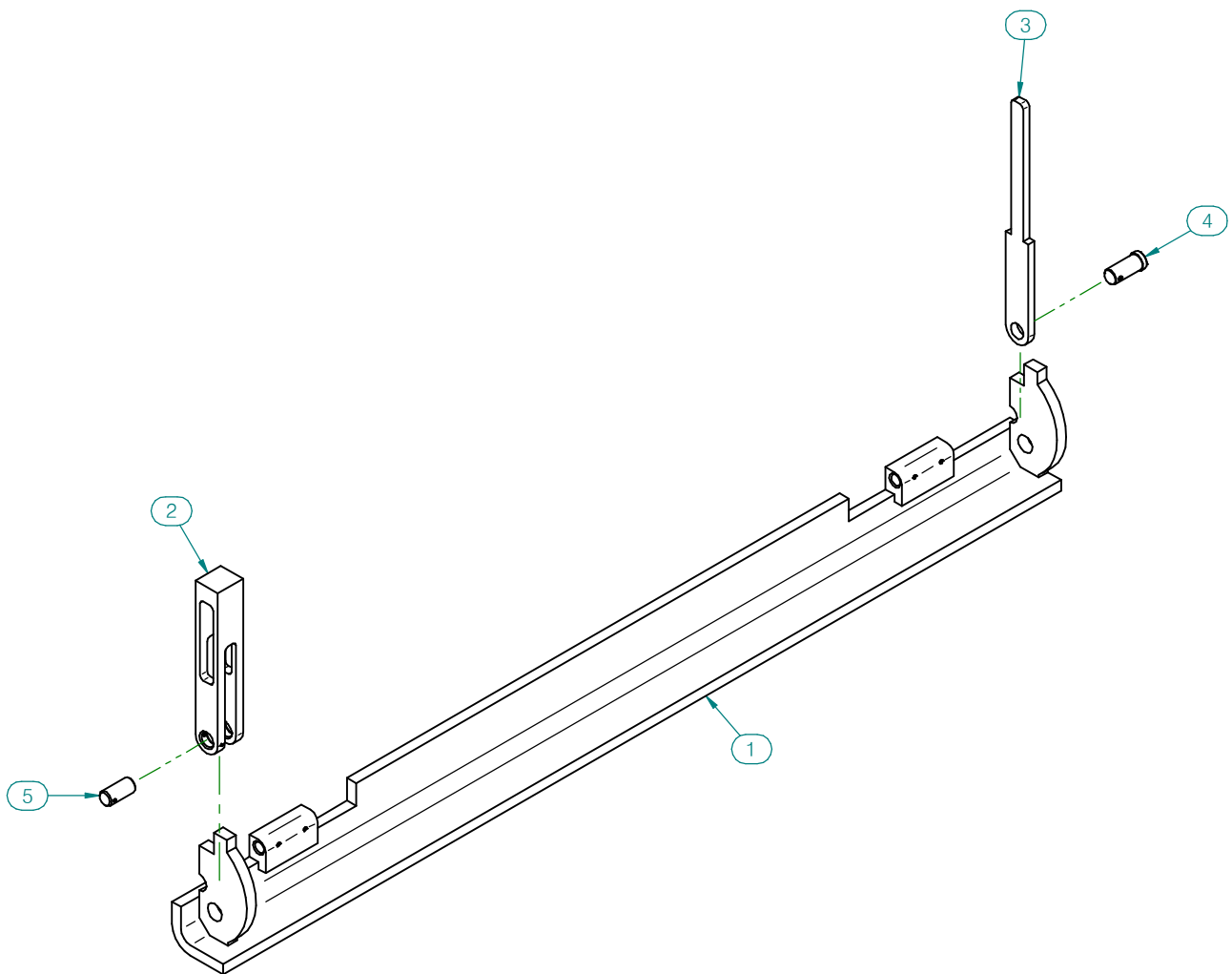

Electric Scissors Lift <SSL-1932N>

as at : 04/2017

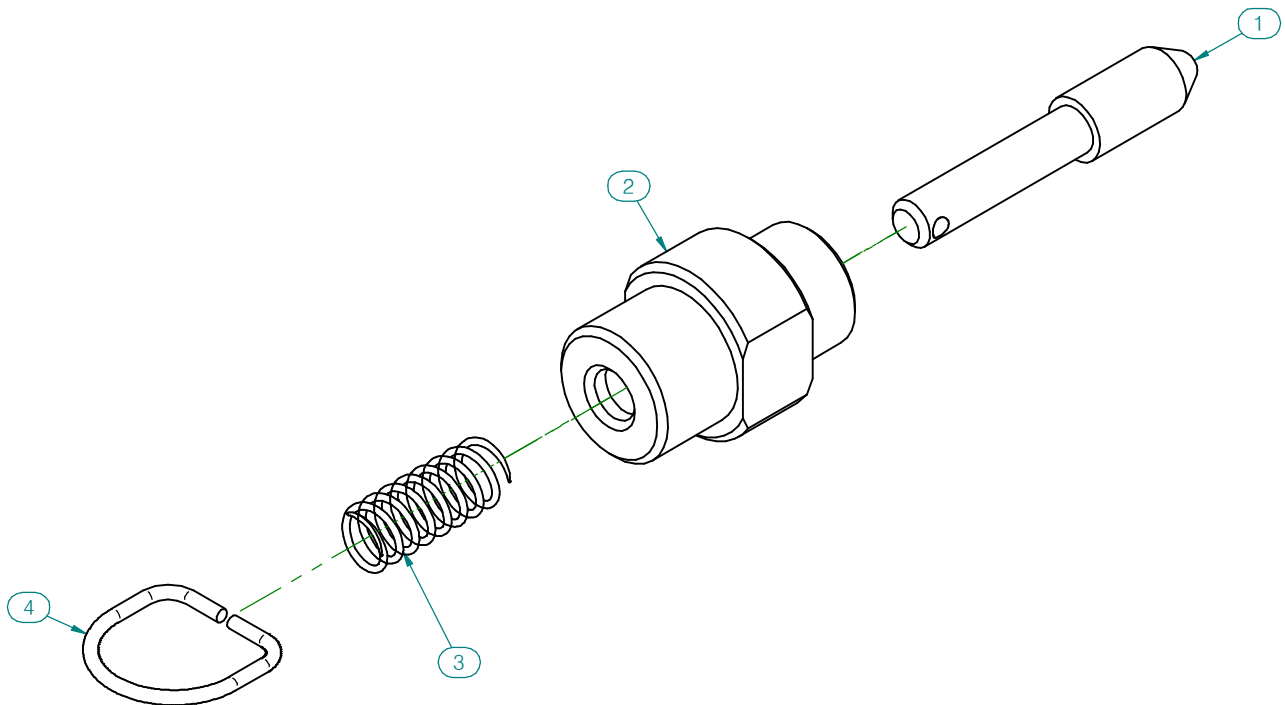

Electric Scissors Lift <SSL-1932N>

as at : 04/2017

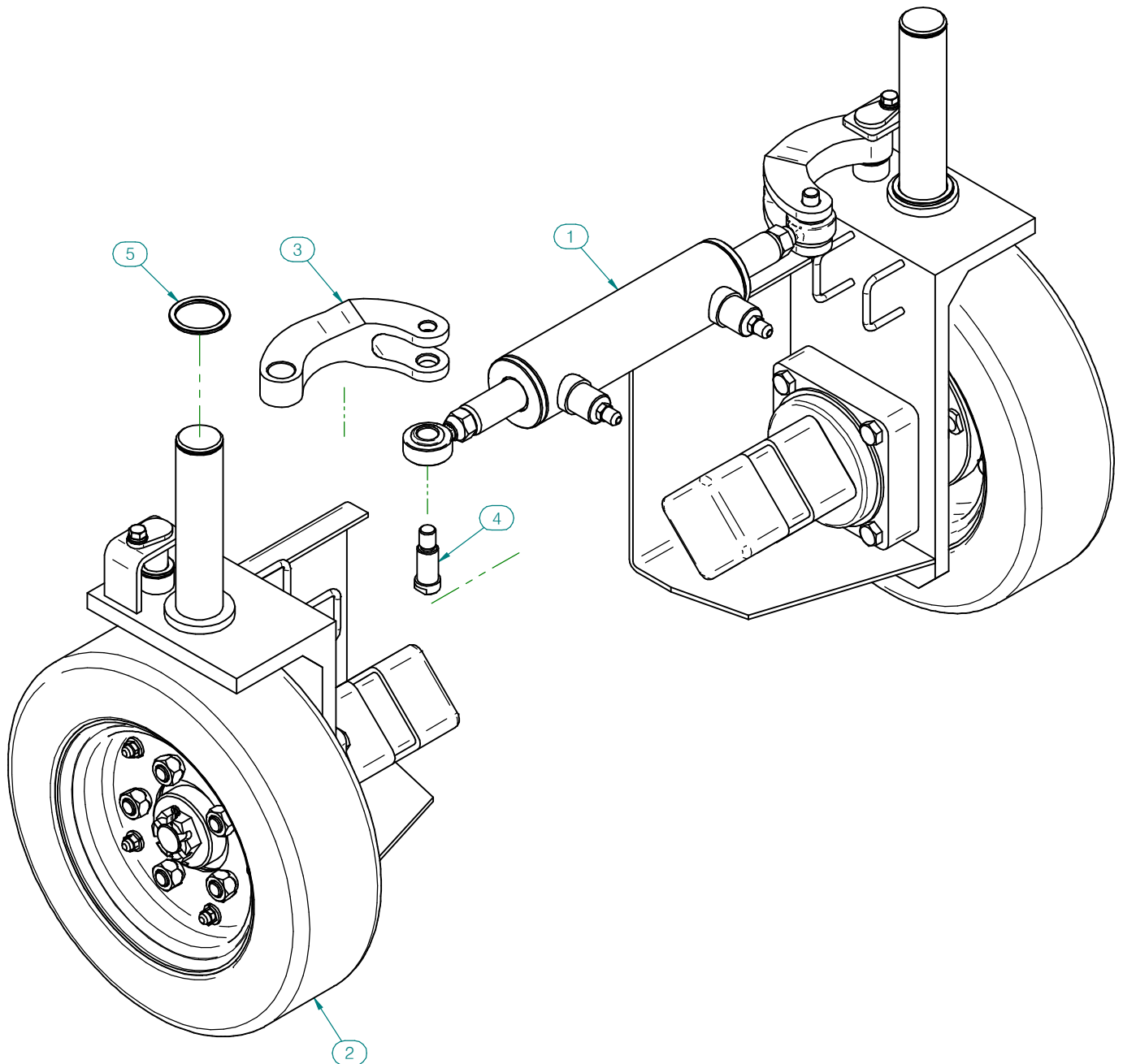

Electric Scissors Lift <SSL-1932N>

as at : 04/2017

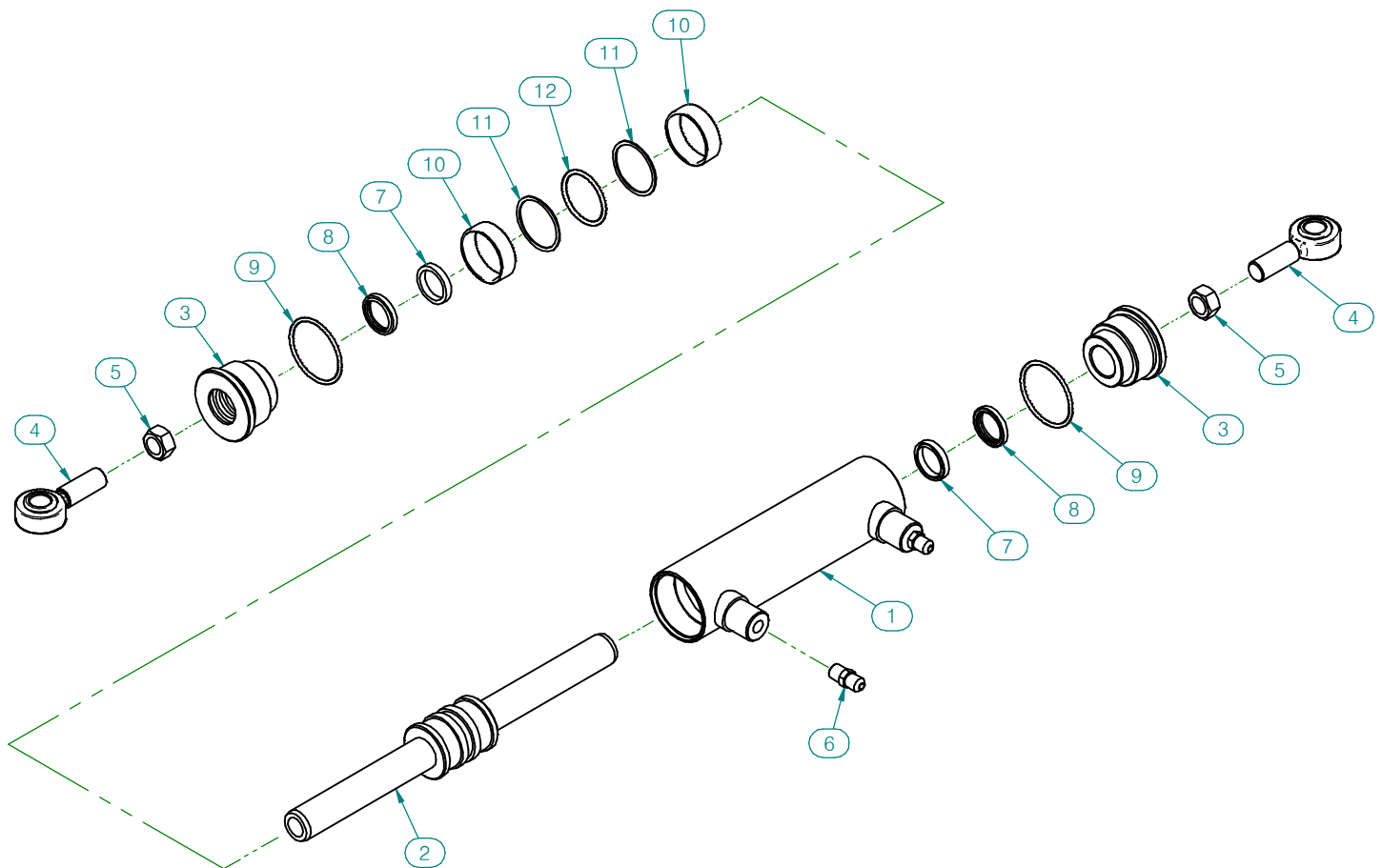

Electric Scissors Lift <SSL-1932N>

as at : 04/2017

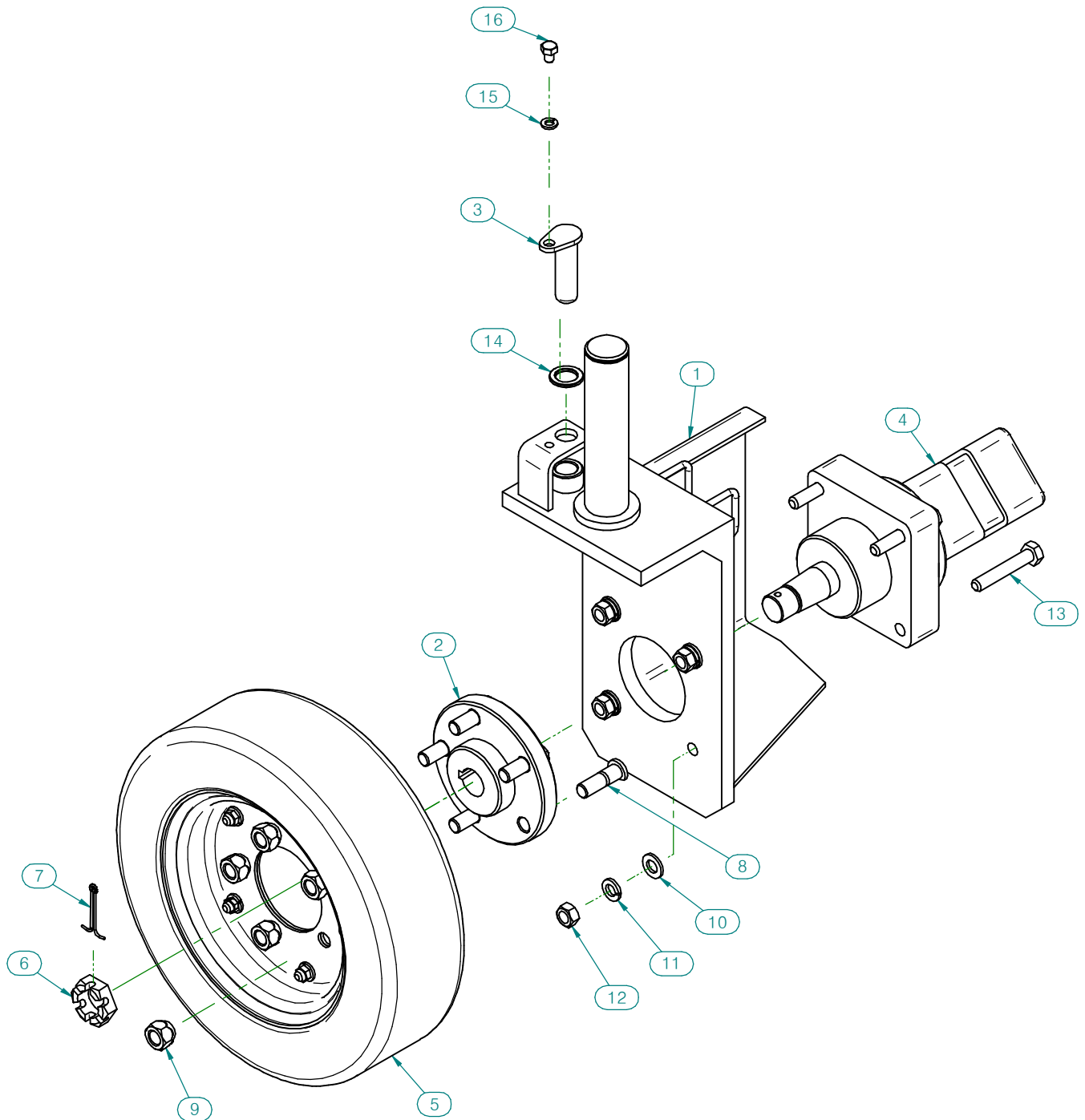

Electric Scissors Lift <SSL-1932N>

as at : 04/2017

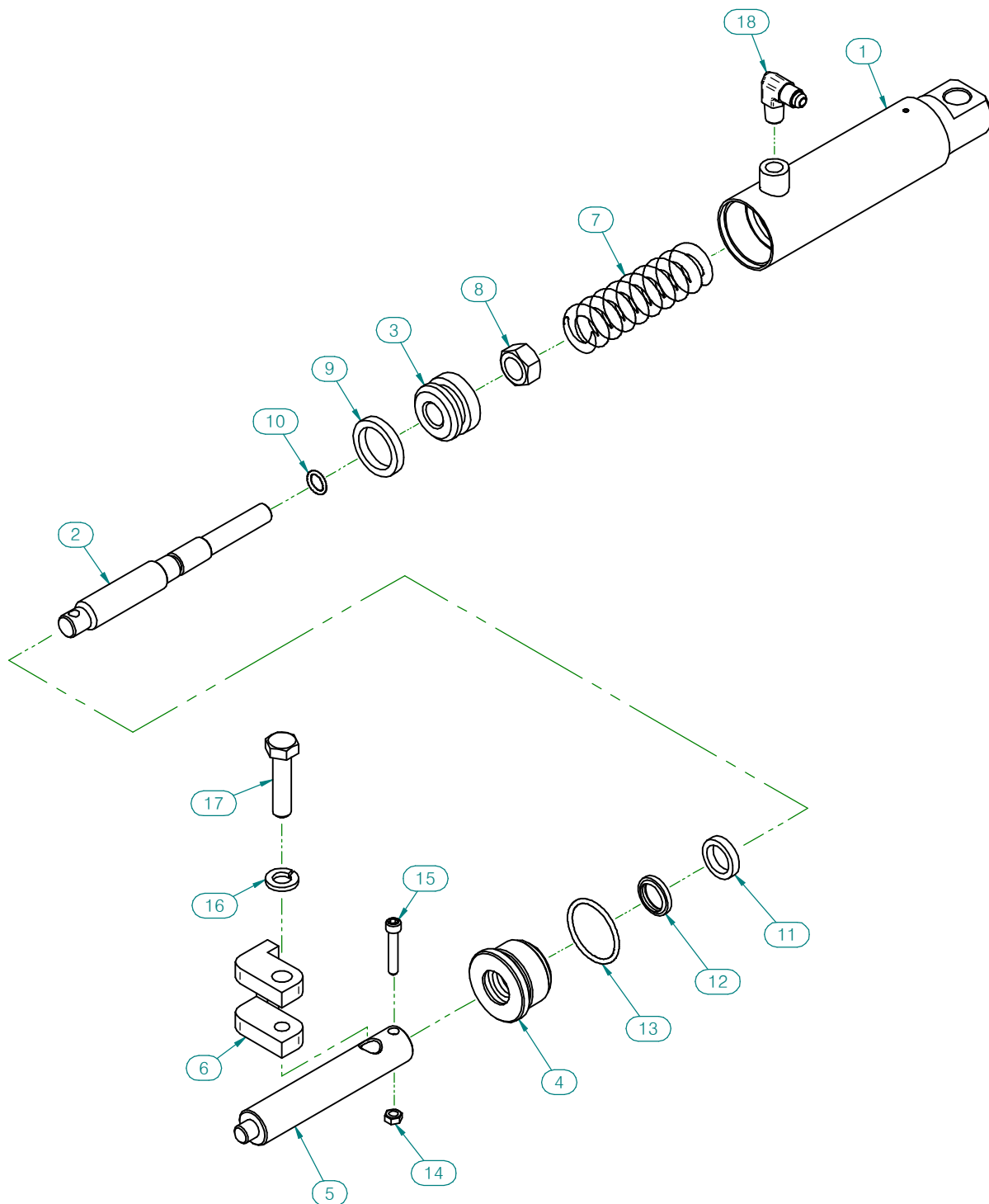

Electric Scissors Lift <SSL-1932N>

as at : 04/2017

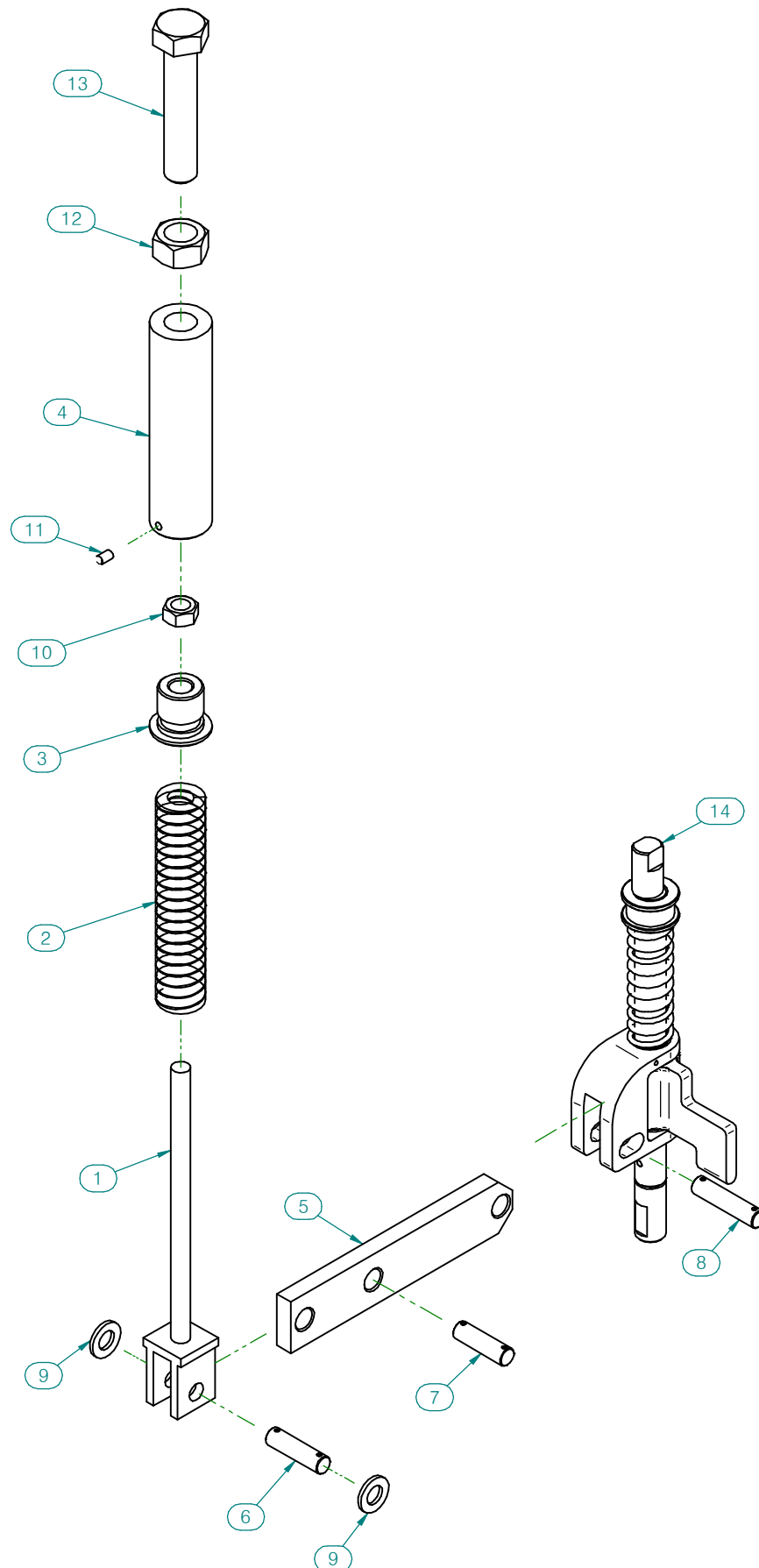

Electric Scissors Lift <SSL-1932N>

as at : 04/2017

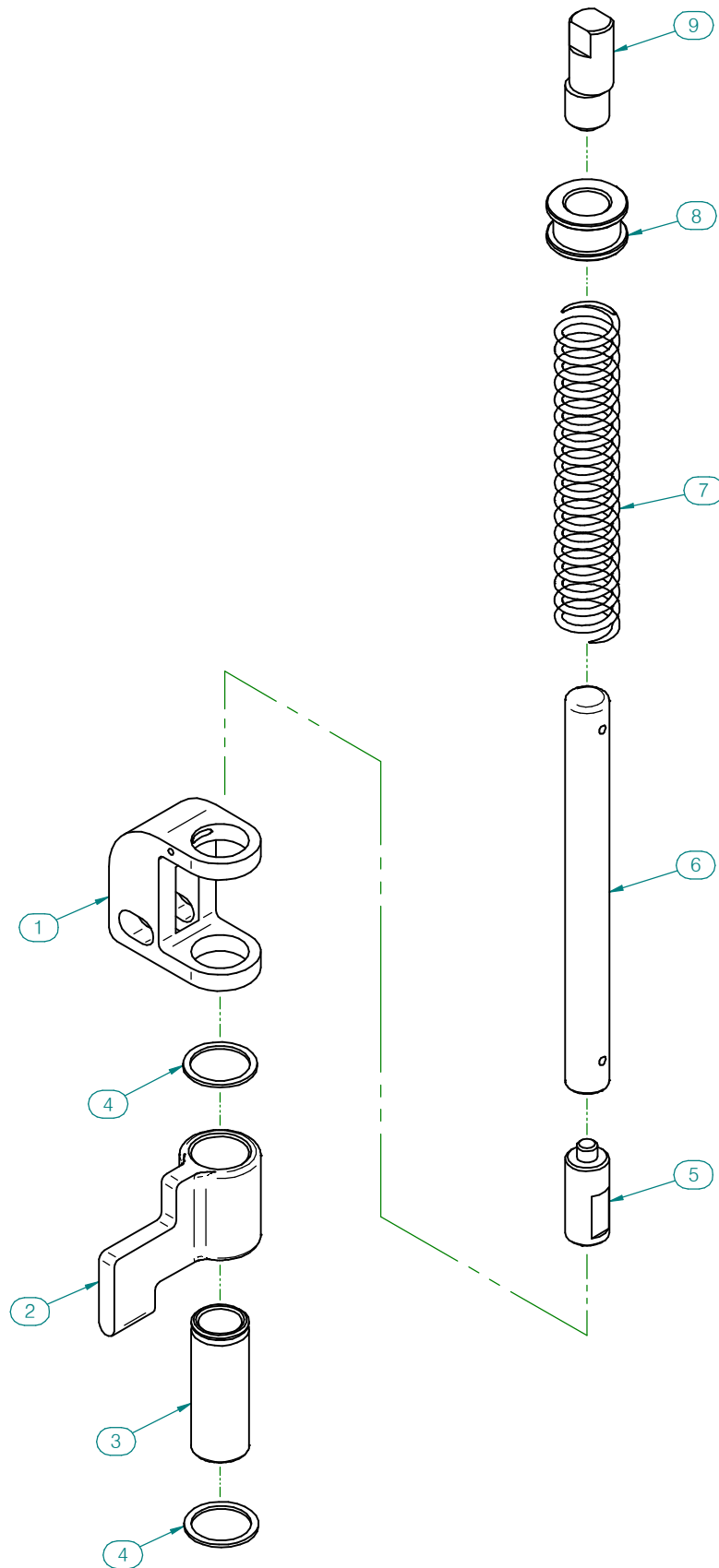

Electric Scissors Lift <SSL-1932N>

as at : 04/2017

Electric Scissors Lift <SSL-1932N>

as at : 04/2017

SECTION 5 Hydraulic & Electric System

Platform Accessories	5-1
Joy Stick Box Component	5-2
Control Panel Component	5-3
Unit Box Component	5-4
Hydraulic Block Assembly	5-5
Hydraulic Motor Component	5-6
Battery Box Component	5-7

Electric Scissors Lift <SSL-1932N>

as at : 04/2017



Electric Scissors Lift <SSL-1932N>

as at : 04/2017

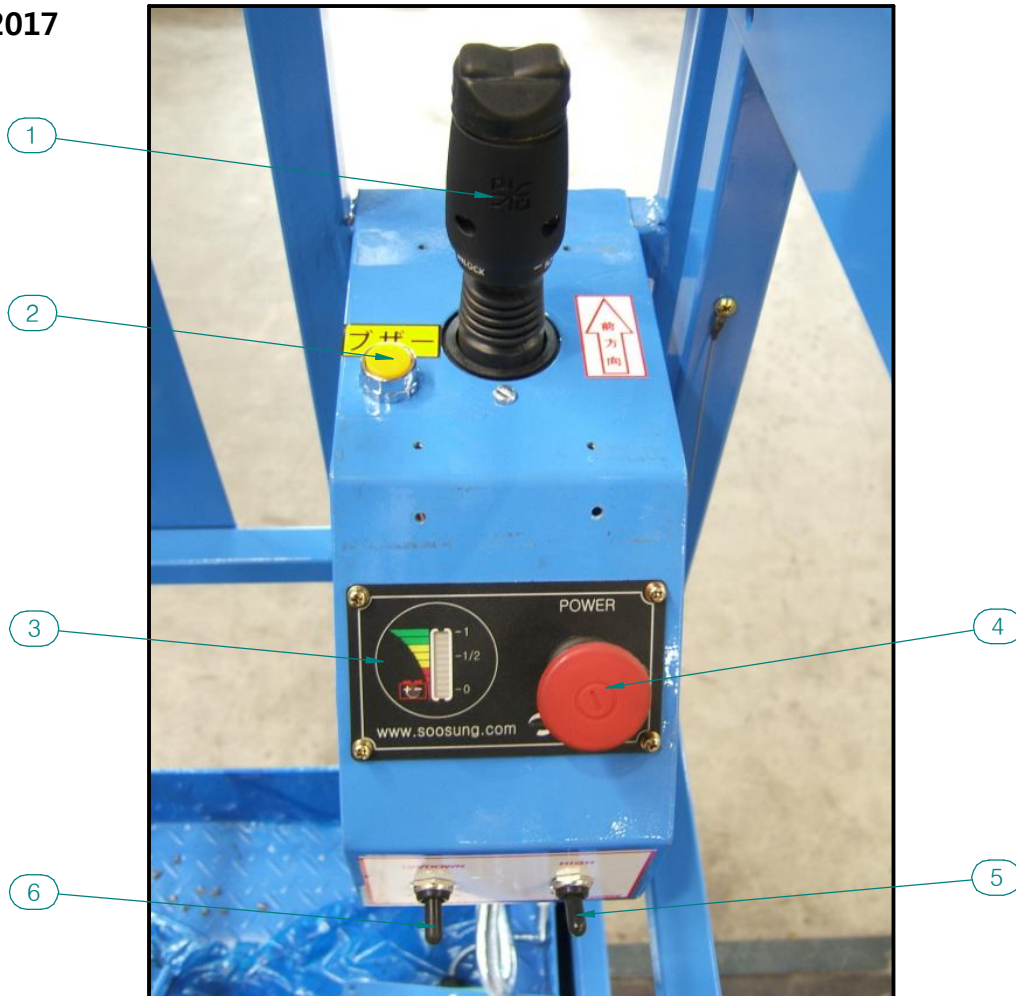

Electric Scissors Lift <SSL-1932N>

as at : 04/2017

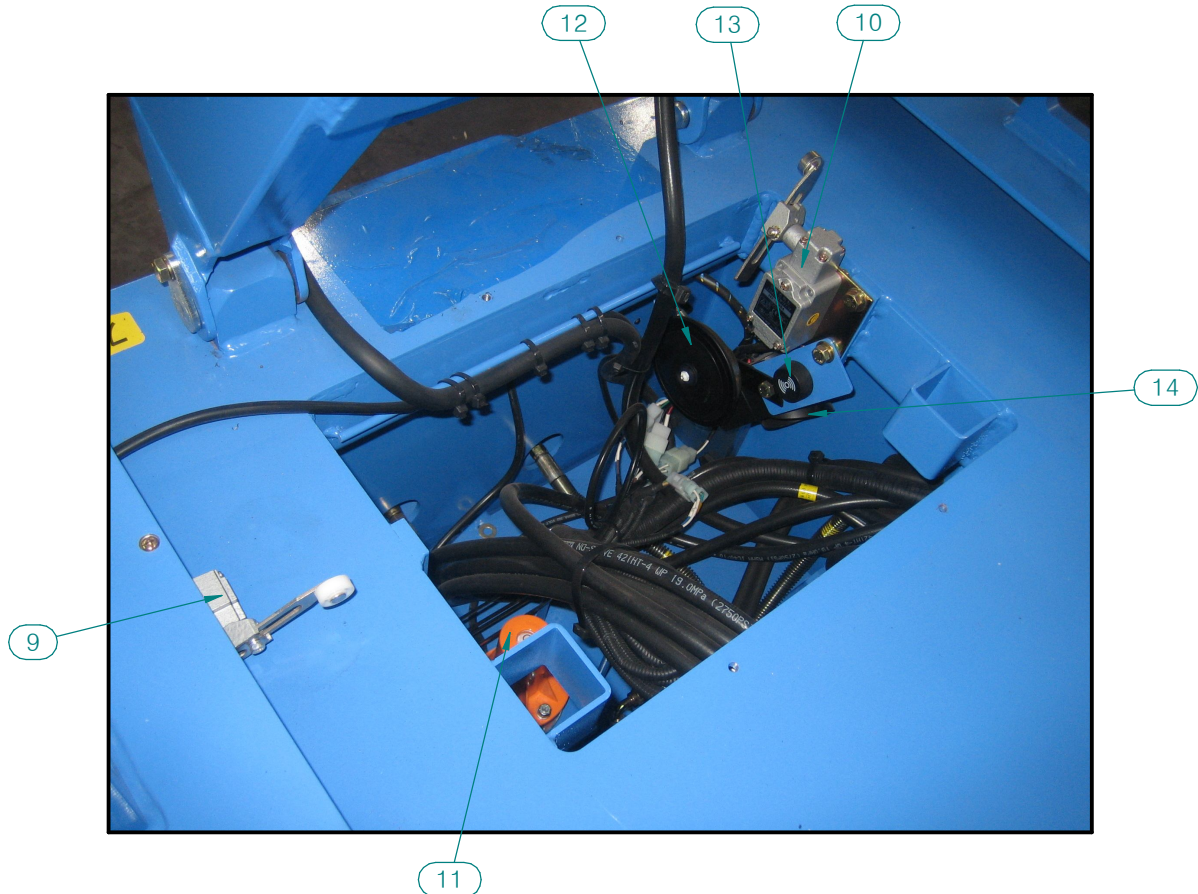
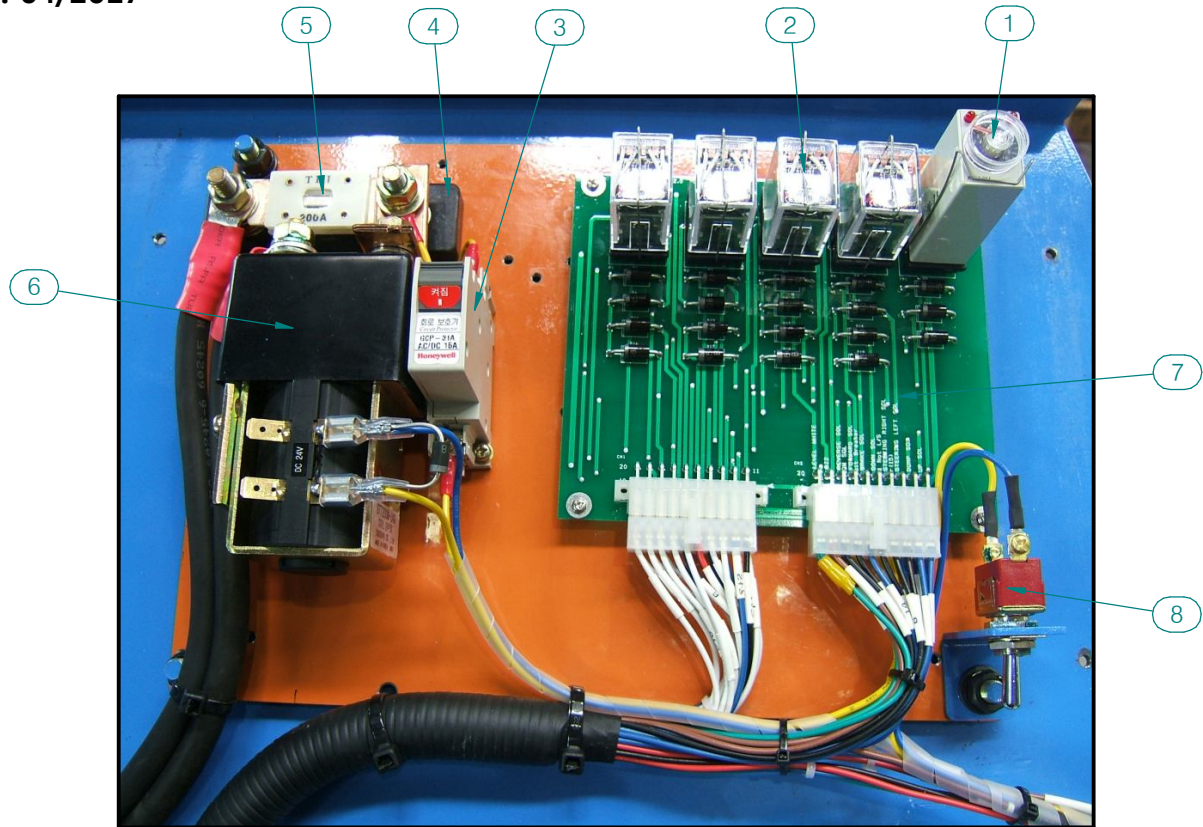

Electric Scissors Lift <SSL-1932N>

as at : 04/2017

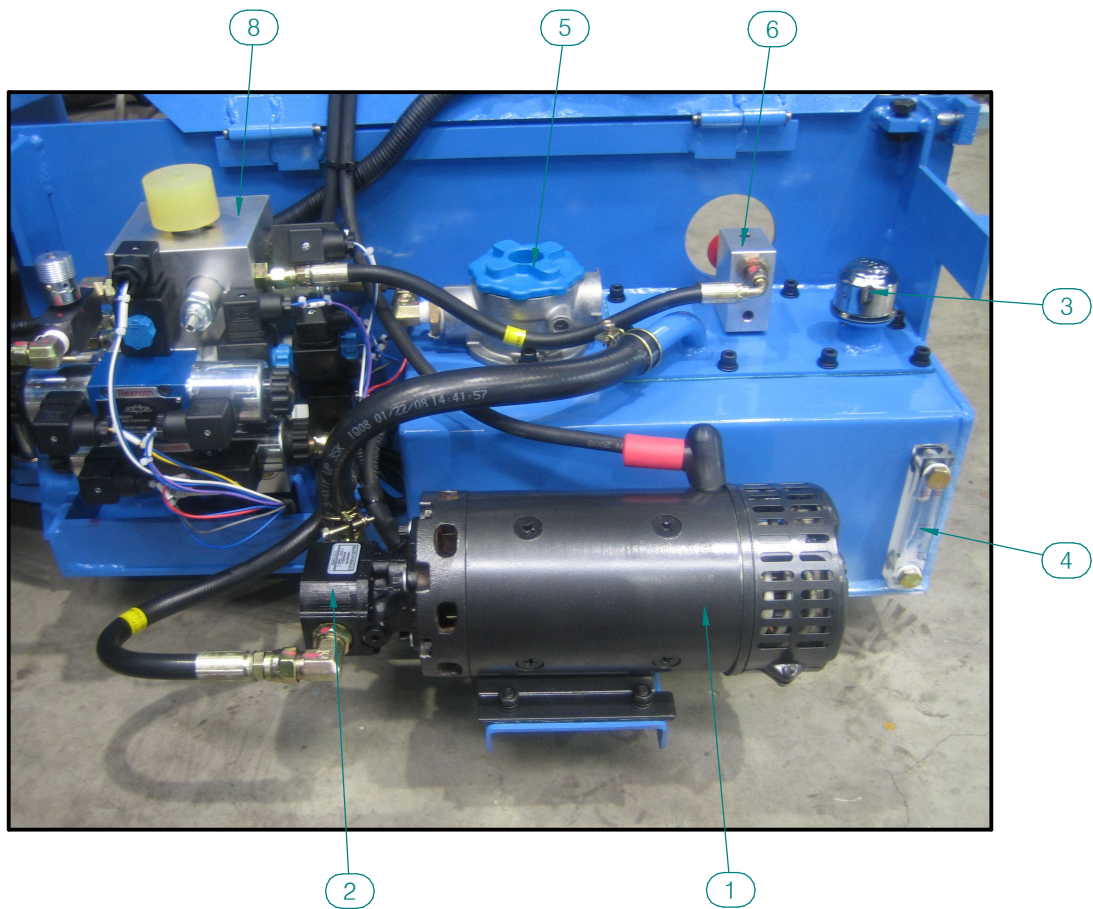

Electric Scissors Lift <SSL-1932N>

as at : 04/2017

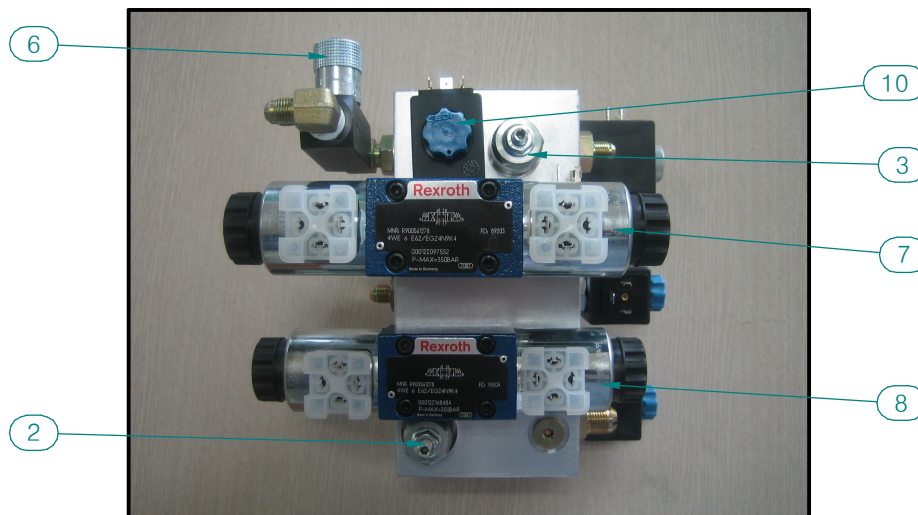
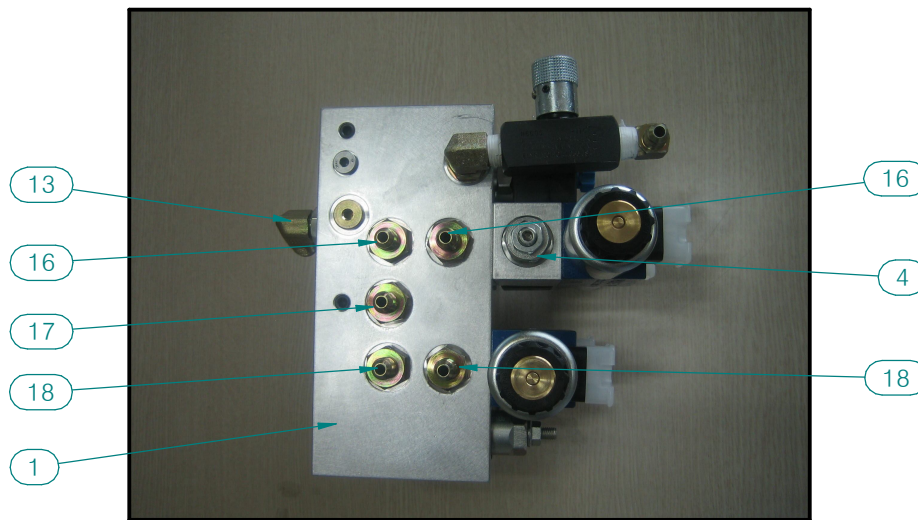

Electric Scissors Lift <SSL-1932N>

as at : 04/2017

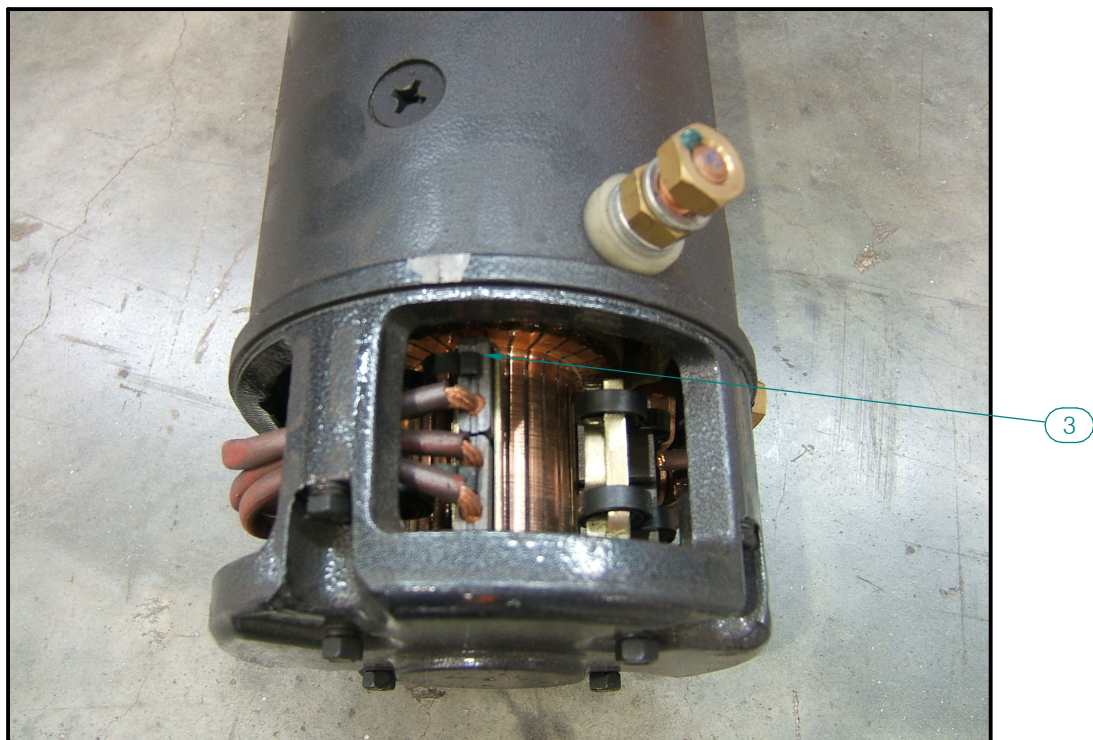
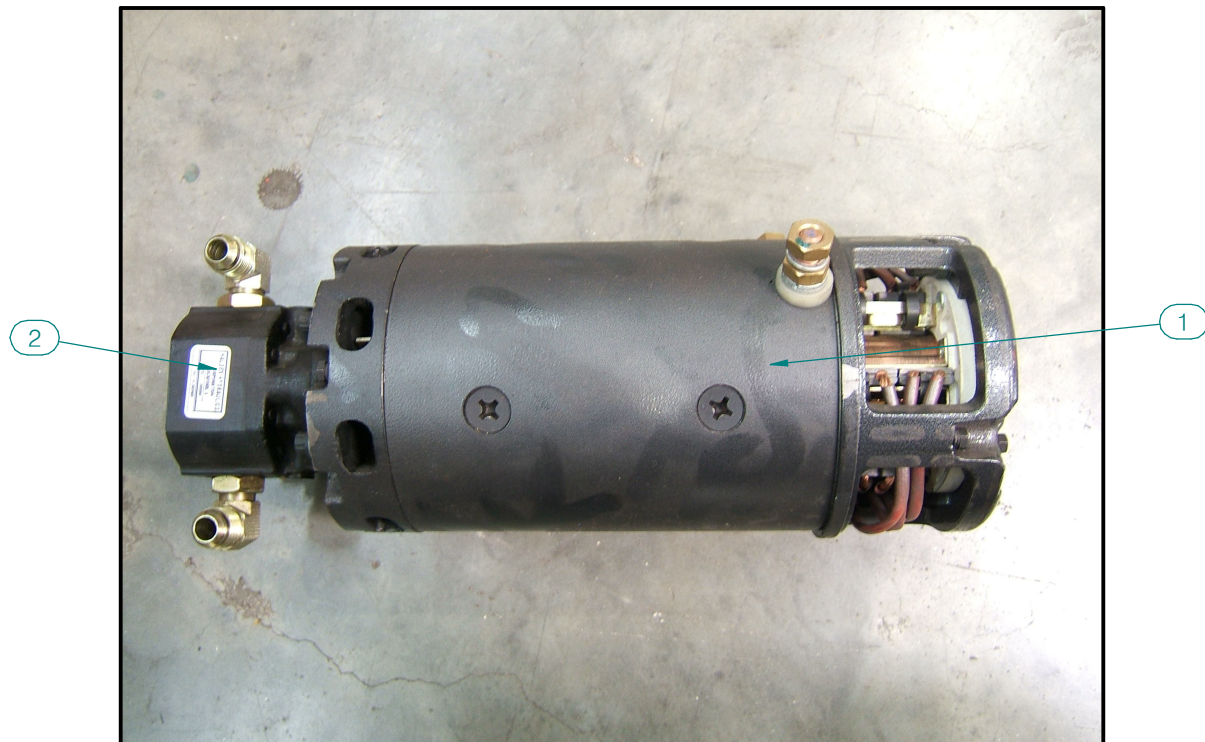

Electric Scissors Lift <SSL-1932N>

as at : 04/2017



